

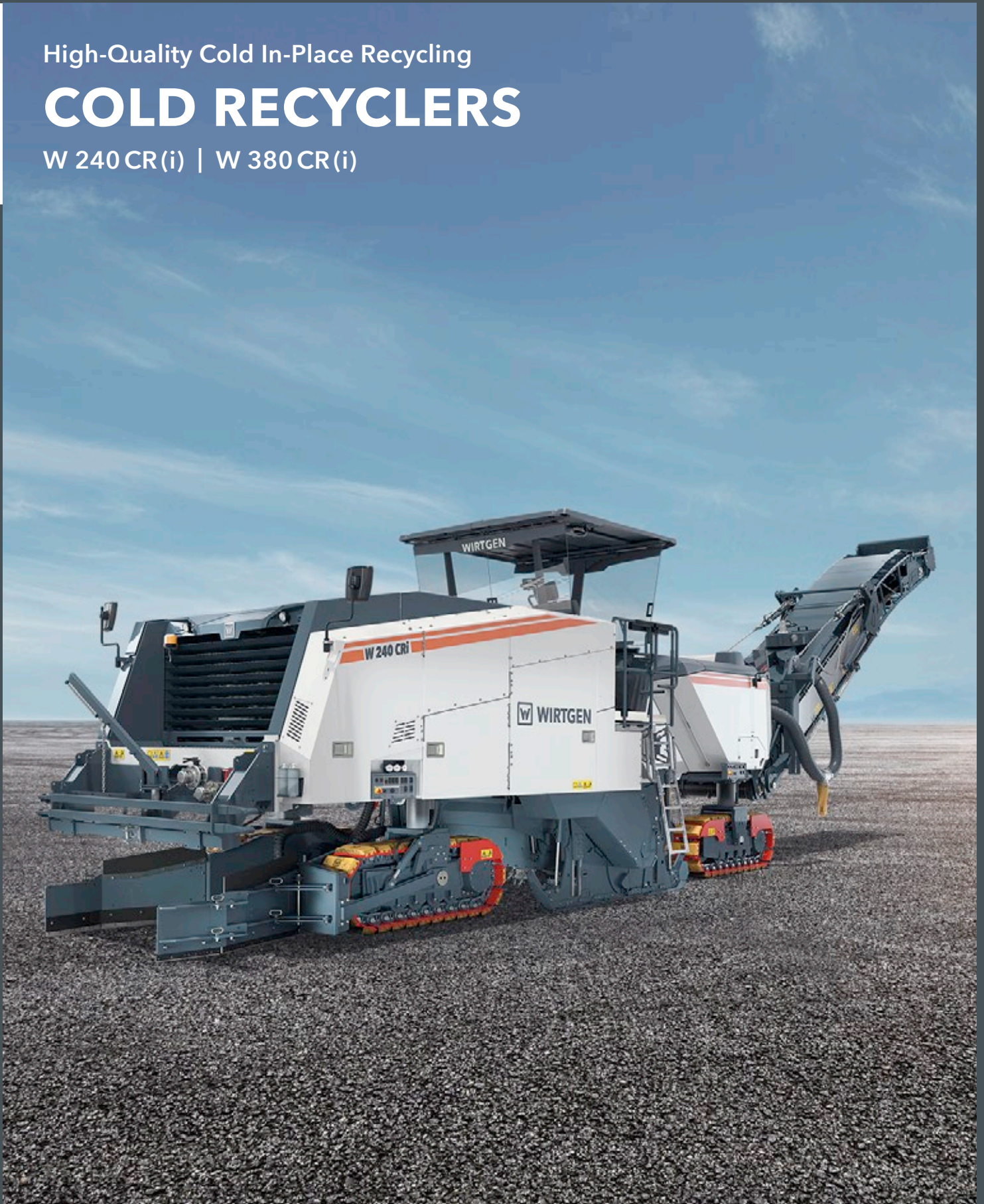

High-Quality Cold In-Place Recycling

COLD RECYCLERS

W 240 CR(i) | W 380 CR(i)



HIGH-QUALITY COLD IN-PLACE RECYCLING



Machines from the CR series are used as part of a paving train for cost-effective cold in-place recycling of road pavements in a single pass through the addition of cement, water and/or bitumen emulsion or foamed bitumen at a mixing performance of up to 800 t/h.

The high-performance W 240 CR(i) with rear loading and a working width of 2,350 mm is ideal for the rehabilitation of road pavements on construction sites with limited space and can also be transported easily from job to job as a single unit.

The high-performance W 380 CR(i) with rear loading and a working width of 3,800 mm is used for rehabilitating full, very wide road surfaces at an extremely high daily productivity.

Lateral pre-milling gives the cold recyclers the flexibility needed to rehabilitate road pavements in a single pass, even at widths exceeding the machine's working width.

If required, cold recyclers can also be used as high-performance milling machines or for the granulation of pavement structures.

WIRTGEN COLD RECYCLERS AND SOIL STABILIZERS

TRACTOR-TOWED STABILIZERS (WS SERIES)

- > Working width up to 2,500 mm
- > Working depth up to 500 mm

COLD RECYCLERS AND SOIL STABILIZERS (WR SERIES)

- > Working width up to 2,400 mm
- > Working depth up to 560 mm

ROCK CRUSHER (WRC SERIES)

- > Working width up to 2,320 mm
- > Working depth up to 510 mm

COLD RECYCLERS (CR SERIES)

- > Working width up to 3,800 mm
- > Working depth up to 350 mm

MOBILE COLD MIXING PLANT (KMA SERIES)

- > Mixing performance up to
240 t/h

LABORATORY EQUIPMENT

OVERVIEW OF HIGHLIGHTS

Perfectly Equipped

01 Simple Operating Concept

- > Flexible positioning of the main control panels in both directions of operation
- > All machine parameters are displayed on a high-resolution color screen
- > Four large, clearly structured control panels for operation by the ground crew
- > On-board diagnostic system for quick and easy assistance with maintenance procedures
- > Many new automated features enhance ease of operation
- > High-precision **LEVEL PRO** leveling system comprising different sensor models

02 Perfection in Visibility, Comfort and Ergonomic Design

- > Optimized machine geometry ensures perfect visibility
- > High-quality camera system comprising up to seven cameras
- > Clearly structured, adaptable operator's platform including canopy
- > Powerful LED lighting system for night operations
- > Easy start-up and quick modification of the machine to match the specific application



03 Tremendous Performance

- > High-powered, high-torque diesel engine
- > Minimized engine noise emissions allow around-the-clock operations in urban environments
- > Intelligent engine-machine management system for maximum advance rates
- > All-track drive (ASC) and fourfold full-floating lifting column feature ensure optimum traction
- > Direct mechanical rotor drive ensures high efficiency
- > High-capacity folding and slewing discharge conveyor with continuously adjustable belt speed
- > Controlled transfer of excess material into trucks via the discharge conveyor

04 High-Precision, Reliable Injection Systems

- > Integrated injection systems for water, bitumen emulsion and foamed bitumen
- > **VARIO** injection bar - adjustable, variable nozzle cross-section for constant, volume-independent injection pressure
- > Metering panel with screen for reliable operation and easy monitoring of binder metering
- > Electrically heated injection system for bitumen and bitumen emulsion, including filter
- > Innovative process water monitoring for the production of foamed bitumen
- > Automatic self-cleaning and flushing feature for high functional reliability of the injection nozzles

05 Powerful and Efficient Milling and Mixing Unit

- > Optimally designed milling and mixing unit for cold recycling or front-loading operation (milling)
- > Extremely wear-resistant quick-change toolholder system **HT22**
- > Hydraulic rotor-turning device and hydraulic and/or pneumatic pick ejector for easy pick changes
- > Modular milling drum assembly **MCS EXTEND** (Multiple Cutting System), available for working widths of 3.2 m, 3.5 m, and 3.8 m



COLD RECYCLING WITH INTEGRATED REAR LOADING

- 01** STREUMASTER binder spreader
- 02** Water tanker truck
- 03** Binder tanker truck

- 04** WIRTGEN cold recyclers of the CR Series
- 05** VÖGELE asphalt paver

- 06** HAMM tandem roller
- 07** HAMM pneumatic-tyred roller

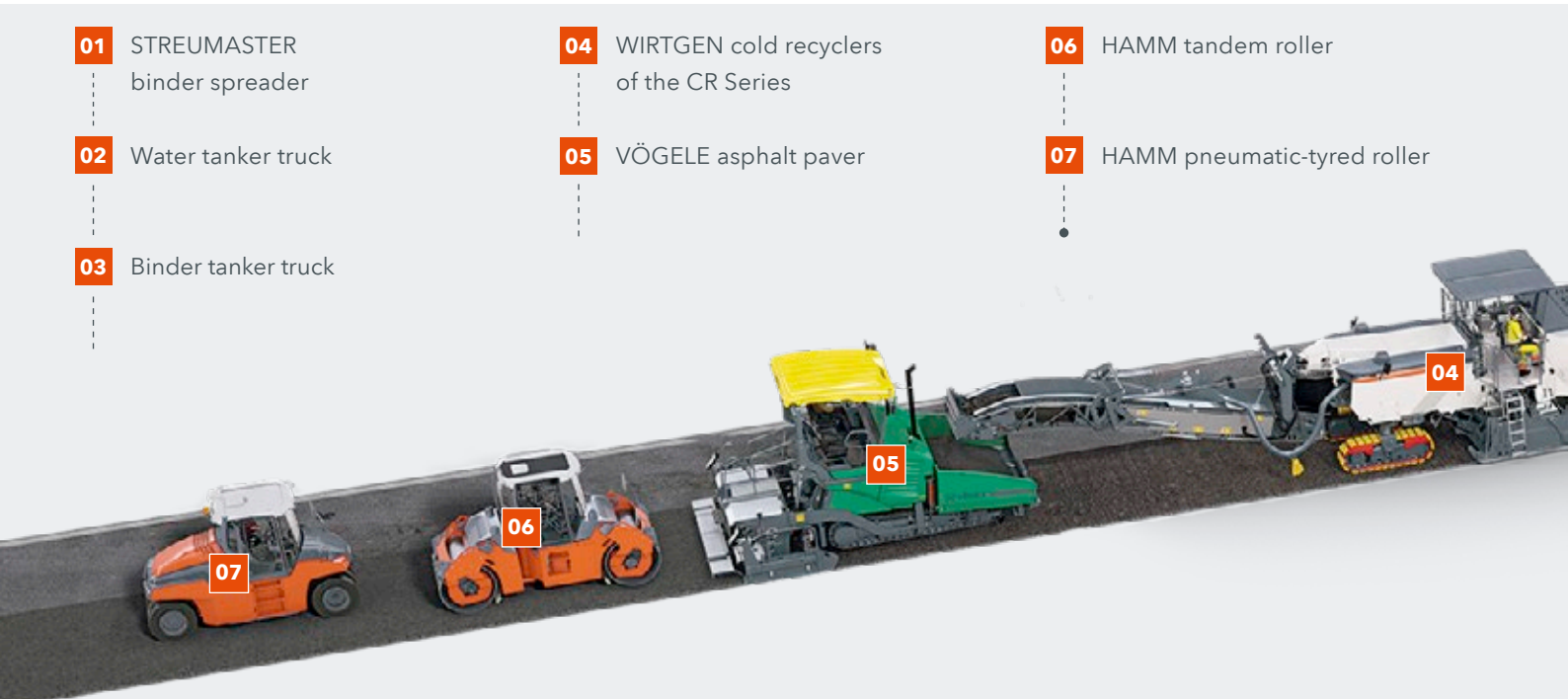

02

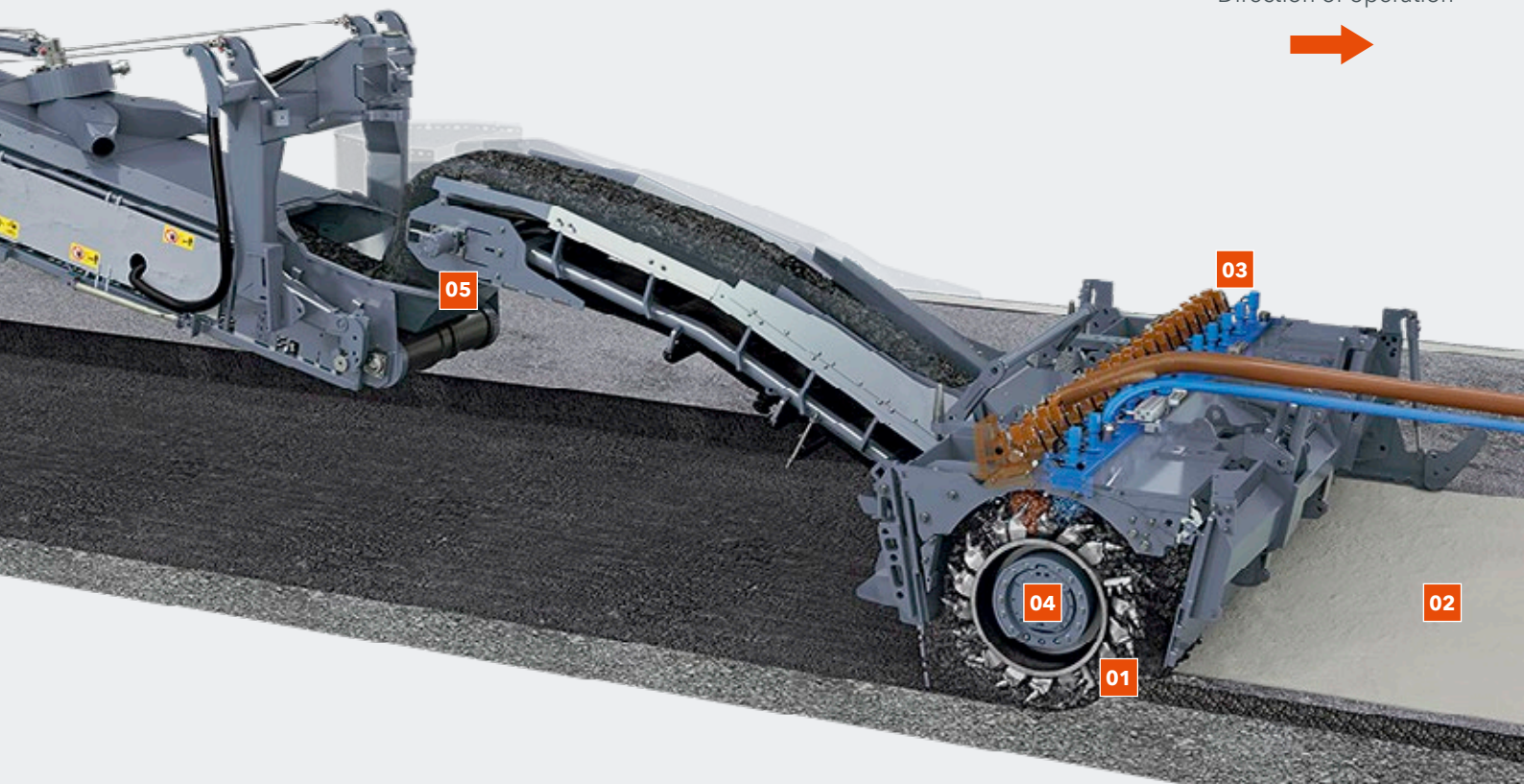

Cold Recycling Train with the CR Series

The STREUMASTER binding-agent spreader pre-spreads cement or lime and is followed by water and binding-agent tank trucks. The milling and mixing rotor granulates the asphalt layers. The pre-spread cement is mixed in at the same time while water and bitumen emulsion or foamed bitumen are injected into the mixing chamber via injection bars.

The recycled construction material is picked up by the conveyor system and transported right into the material hopper of the VÖGELE asphalt paver for placing. Final compaction of the material is then effected by HAMM rollers.



Direction of operation



01

- 01** Damaged asphalt layer
- 02** Pre-spread binding agent (e.g. cement or lime)
- 03** Injection bars for water and binders
- 04** Milling and mixing rotor
- 05** Primary conveyor and discharge conveyor for material transfer to the asphalt paver

The robust milling and mixing rotor granulates the damaged asphalt pavement. The granulated material is mixed with injected binders and water in the mixing chamber, thus creating a new homogeneous mix in an in-situ process.

Due to the helical design of the milling and mixing rotor, the recycled mix is conveyed towards the centre and subsequently transported to the material hopper of the asphalt paver via the conveyor system comprising primary and discharge conveyor. The asphalt paver then paves the material true to grade and slope.

01 Cold recycling train with the CR Series

02 Recycling material with the W 380 CR(i) (down-cut)

APPLICATIONS OF THE COLD RECYCLERS

- A** Example of an application with the W 380 CR(i): production of a bituminous-bound base layer with a W 380 CR(i) and a paver (lateral pre-milling enables variable working widths)



- B** Example of an application with the W 380 CR(i): production of a cement-bound base layer with a W 380 CR(i) and a paver (lateral pre-milling enables variable working widths)



- C** Example of an application with the W 240 CR(i): lateral pre-milling and production of a bituminous-bound base layer with a W 240 CR(i) and a paver

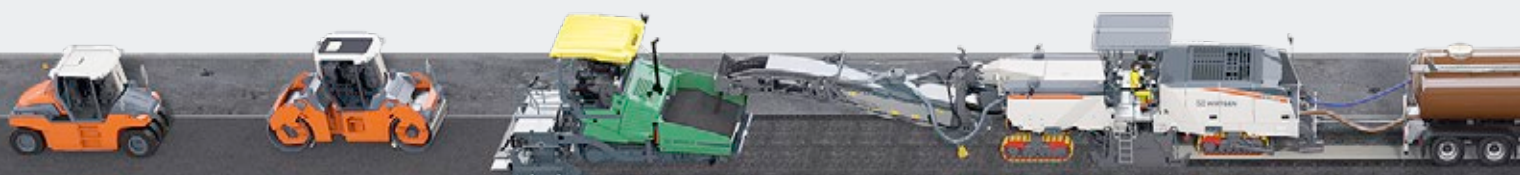

- D** Example of an application with the W 240 CR(i): lateral pre-milling and production of a cement-bound base layer with a W 240 CR(i) and a paver



- E** Example of an application with the W 240 CR(i) / W 380 CR(i): cold milling with the W 240 CR(i) / W 380 CR(i)



SIMPLE OPERATING CONCEPT

Flexible Positioning of the Main Control Panels

Flexible positioning of the two functionally identical, individually adjustable main control panels on the left and right permits the cold recycler to always be operated in line with ergonomic principles, ensuring perfect visibility at the same time. When changing the machine's direction of operation, the control panels are simply mounted on the opposite side of the operator's platform. The machine can also be operated quite easily when standing transverse to the direction of travel.

Display of All Machine Parameters

All important machine and metering parameters can be adjusted and monitored quite easily via the clearly and logically structured control screen.

Four Large Control Panels for the Ground Crew

Four large, clearly structured control consoles enable numerous functions such as adjusting the material guide plates, side plates, rotor plate or machine height to be operated by the ground crew.

On-Board Diagnostic System

The machine's automatic self-diagnostic system autonomously monitors valves, sensors and control components. Numerous clearly visualized pages provide quick and accurate information on the machine's current operating parameters. In addition, the machine offers ready access to all servicing points.

01



Ergonomics for Every Job

Flexibly positionable control panels

Complete Control

Extra panels for operating personnel

Many New Automated Features

Operation of the machine is simplified enormously by a multitude of new automated features such as the alignment of the machine parallel to the pavement surface (PTS), load-controlled conveyor belt speed, or cleaning of the injection systems.

High-Precision LEVEL PRO Leveling System

The tried-and-tested LEVEL PRO leveling system includes control screens for the machine operator and ground crew, as well as a wide variety of different application-specific sensors ensuring precise milling results.



01 The control panels can be adjusted to perfectly meet the different job requirements.

02 The ground crew can easily adjust conveyor settings and the machine's advance rate or monitor metering functions.



PERFECTION IN VISIBILITY, COMFORT AND ERGONOMIC DESIGN

Perfect Visibility

The intelligent geometry of the machine frame provides a perfect view of important areas of the operation regardless of the job to be performed or the machine's working direction. The dual wasp waist, slanting engine cowling and separate viewing channel enable the operator to always keep an eye on both the zero-clearance side and the material loading process.

High-Quality Camera System

The robust camera system comprises up to seven cameras. High-resolution camera images can be simultaneously displayed on different screens. The camera image of the discharge conveyor can, for example, be displayed both on the camera screen and on the metering panel.

Clearly Structured Operator's Platform

The spacious operator's platform, which is equipped with one each stand-up seat left and right, provides ideal ergonomic

conditions for the machine operator to fully focus on his task. In addition, the machine is extremely quiet in operation. The operator's platform can be folded out to offer a workplace even beyond the edge of the machine. Depending on weather conditions, the canopy can additionally be moved to the left or right and extended on either side.

Powerful LED Lighting System

Intelligently arranged, bright LED working lights and LED lighting balloons offer perfect visibility in poor lighting conditions.

Easy Start-Up and Quick Modification

Modifications such as mounting or removing the conveyor or paving screed can be completed within a short period of time. The support arm installed to accommodate the push bar and hoses at the front of the machine additionally facilitates operation during tanker truck changes.



Stress-Free Operating

Large operator's platform

Ideal Overview of Important Working Areas

Practical camera system

- 01** Excellent lighting enables night operations to be completed rapidly and efficiently.
- 02** The operator always has an unobstructed view of the milling edge and discharge conveyor.
- 03** Different camera systems provide a good view of important areas of the operation.



03



Standard camera system comprising one camera:
area in front of the machine



Optional camera system comprising up to seven cameras:
area in front of the machine / front track units / front rotor plate / rear rotor plate / left side of the machine towards the front / paving screed / loading situation

TREMENDOUS PERFORMANCE

High-Torque Diesel Engine

The state-of-the-art diesel engine offers tremendous drive power and a high maximum torque, ensuring fast-paced operation and high production rates even at the maximum milling depth. It permits a wide range of applications at a mixing capacity of up to 800 t/h, making the cold recycler the ideal candidate also for power-sapping operations such as pulverizing hard pavement structures to the specified quality.

Minimized Engine Noise Emissions

Optimized machine settings, effective soundproofing and temperature-controlled fan speed team up to significantly reduce noise emission levels. Our strict environmental standards thus enable operations to continue around the clock even in residential areas.



01

Built to Handle Every Challenge

Powerful engine

Quiet Mover

Focused on low environmental impact

02

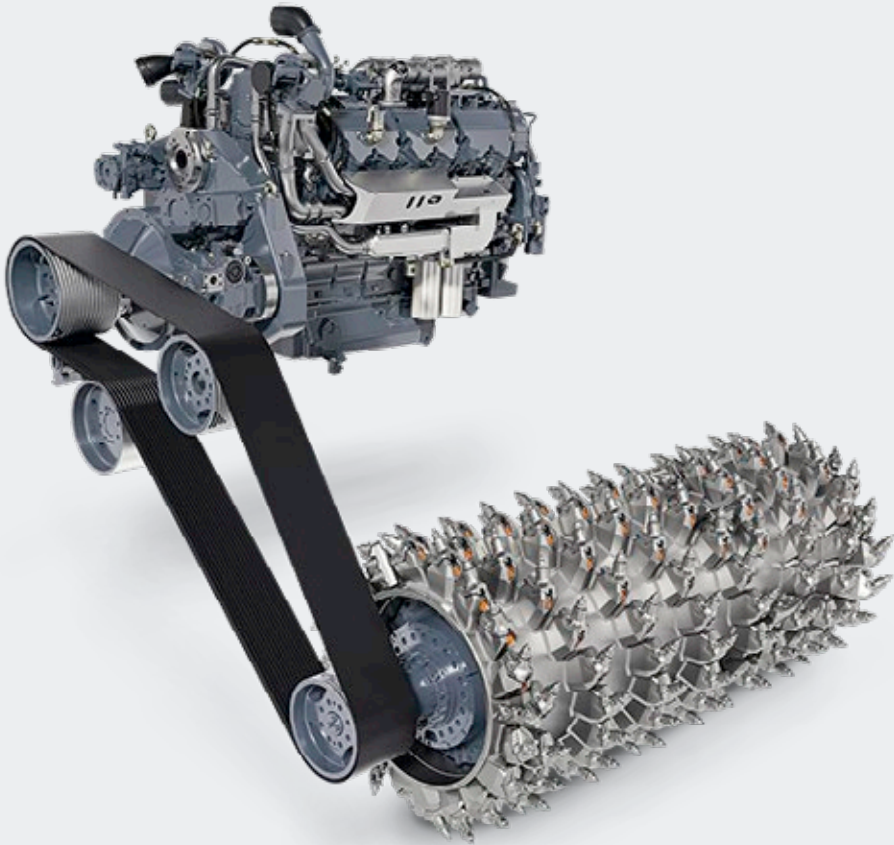

01 Low noise and exhaust emissions, paired with compact machine dimensions, allow operation even in urban environments.

02 The salient features of the cold recycler include three different rotor speeds, high engine power, mechanical rotor drive and speed-controlled fan drive.



TREMENDOUS PERFORMANCE

Intelligent Engine-Machine Management System

The machine's intelligent, fully electronic control system governs not only the interplay of important machine components but also the advance rate of the cold recycler in accordance with the machine and engine load. This relieves the machine operator of a tremendous part of his workload while at the same time improving machine performance. The machine's state-of-the-art technology reduces diesel consumption as well as CO₂ and noise emissions.

All-Track Drive (Asc) and Fourfold Full-Floating Lifting Column Feature

Quick manoeuvring and small turning radii are guaranteed by the machine's smooth hydraulic all-track steering system.

Electronic traction control ensures optimum driving performance regardless of ground conditions. The perfectly balanced fourfold full-floating feature and increased travel of the lifting columns can be relied on to not only quickly level out any ground irregularities but to also facilitate machine loading.

Direct Mechanical Rotor Drive

The mechanical milling and mixing rotor drive permits consistently high performance rates at high efficiency levels. This is essential in situations where high mixing performance is required - e.g. when mixing laterally pre-milled material placed in front of the cold recycler with the layer still to be granulated.



01

Lower Carbon Emissions, Higher Performance

Smart machine control

Optimal Traction

All-track steering

02

- 01** The high-performance cold recycling train with the W 240 CRi also reduces emissions and conserves valuable resources.
- 02** Lateral premilling enables the cold recycler to rehabilitate even wider road surfaces.



High-Capacity Folding and Slewing Discharge Conveyor

The cold recycler is equipped with a powerful conveyor system with extremely high conveying capacity. The slewing, height-adjustable discharge conveyor with adjustable belt speed enables huge amounts of material to be moved with speed and flexibility. The discharge conveyor can additionally be mounted or removed quickly and easily as required.

Controlled Transfer of Excess Material

Excess material can be removed from the ongoing process and transferred to a truck at either side with the slewing discharge conveyor.

HIGH-PRECISION, RELIABLE INJECTION SYSTEMS

Integrated Injection Systems

Precise injection systems controlled by micro-controller guarantee exact metering of the various additives such as water and bitumen emulsion or foamed bitumen. Depending on the application, several injection bars can be installed to allow simultaneous addition of different binding agents.

The hose connections and pumps of the injection systems are located at the front of the machine close to the tanker trucks to allow quick truck changes. Low suction points ensure good supply to the pumps and easy venting. Feed hoses installed in the machine frame provide a clear view of the process.

Constant Injection Pressure

The nozzles of the **VARIO** injection bars for foamed bitumen, bitumen emulsion and water feature a variable cross-section. This enables constant injection pressure to be maintained, regardless of the volume. This ensures ideal and even distribution in the milling and mixing unit across the defined spraying width, and thus assures the homogeneity of the mix. The spraying width can also be adjusted to meet specific requirements.

Metering Panel For Easy Monitoring Of Binder Metering

The metering panel with screen can be used to adjust and monitor all important parameters related to binder metering. The main functions of the machine can also be selected via the metering panel.



Perfect Injection Pressure
VARIO injection bars

Precise Metering
Separate binding agent metering panel

Low spraying volume

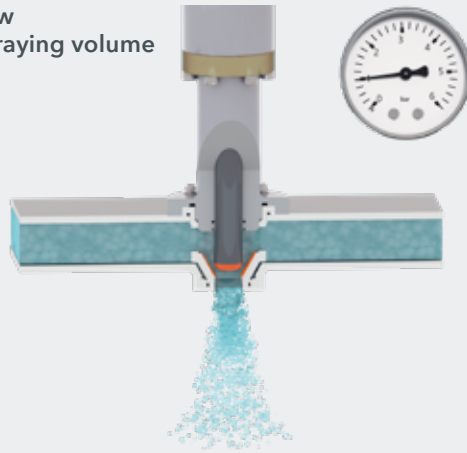

High spraying volume

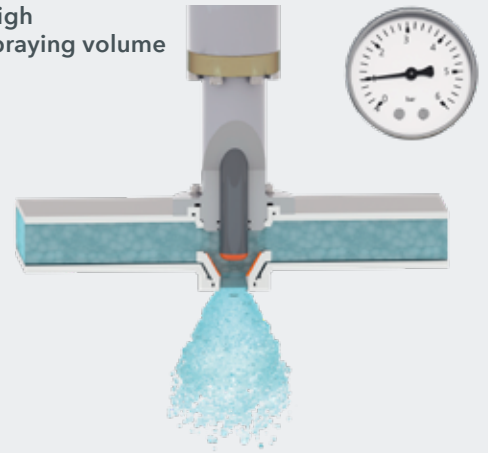

Cleaning - e.g. manual pricking

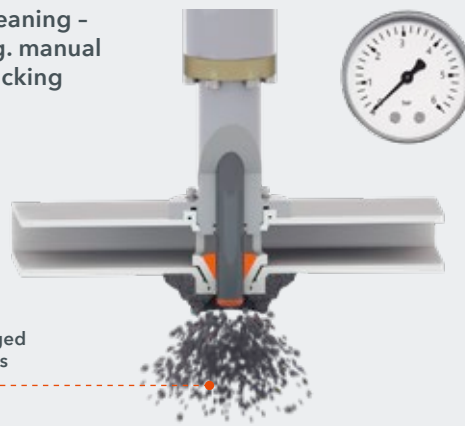

Dislodged residues

Functional principle: variable nozzle cross-section of the injection bar for water or bitumen emulsion.

01 The injection system feeds water into the mixing chamber in a microcontroller-controlled process and in accordance with the mix formulation to achieve the optimum moisture content.

02 Two injection bars can be operated simultaneously when adding water and bitumen emulsion.



02

01

02

- 01** Injection bar for bitumen emulsion
- 02** Injection bars for water

HIGH-PRECISION, RELIABLE INJECTION SYSTEMS

Electrically Heated Bitumen System

The bitumen-carrying components are electrically heated and fitted with short feed hoses to ensure easy, reliable processing of the hot bitumen at temperatures of up to 180 °C. The temperature of the bitumen injection system can be adjusted in line with requirements so that it can also be used for processing bitumen emulsion at lower temperatures.

Process Water Monitoring for the Production of Foamed Bitumen

The continuous, unobstructed flow of the amount of process water injected into the expansion chamber during foamed bitumen production is monitored and displayed via the additional process water monitoring feature.

Automatic Cleaning Processes

As the work progresses, individual nozzles are regularly closed in rapid sequence. This results in a sudden increase of pressure, which serves to clean the other open nozzle outlets on the VARIO injection bar. In addition, the nozzles can be cleaned manually by freeing the closing hydraulic cylinder at the nozzle outlet, when the work is interrupted or finished.

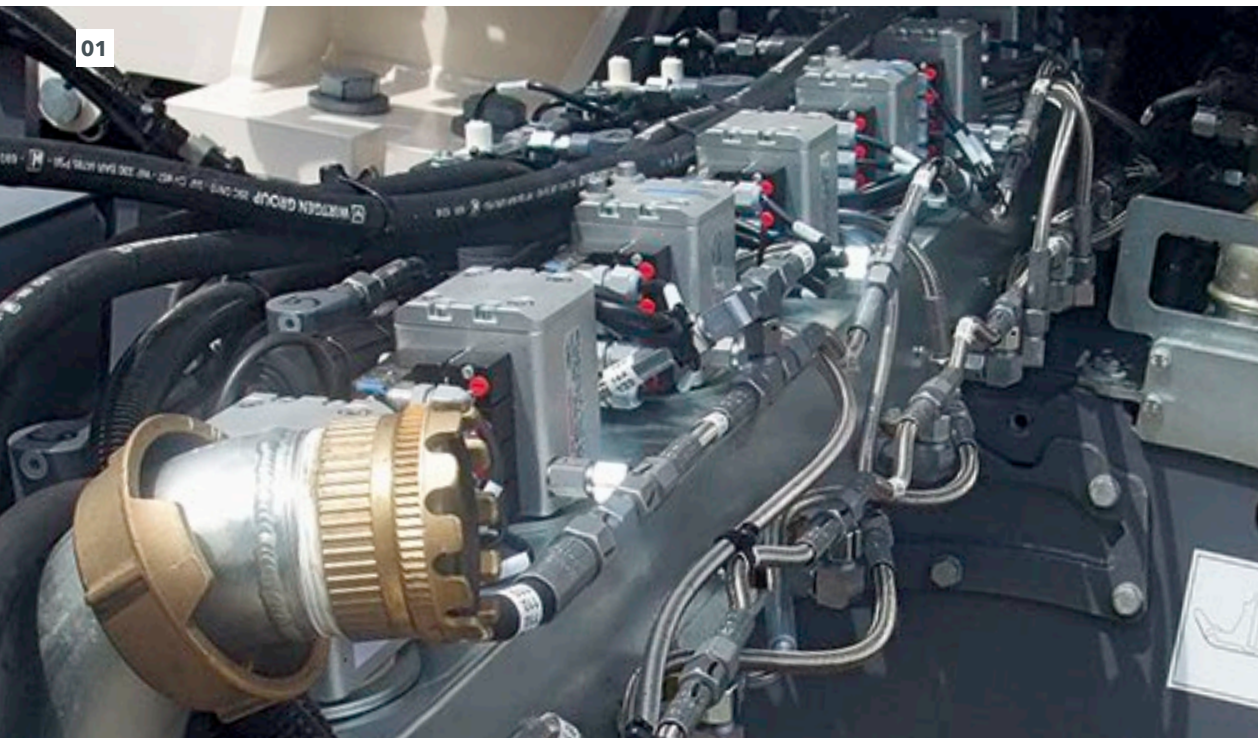

- 01** For base layers of exceptionally high quality, foamed bitumen is produced in separate expansion chambers by injecting water and compressed air into bitumen previously heated to approx. 180 °C.
- 02** The microcontroller-controlled injection system injects foamed bitumen and water into the mixing chamber in precisely metered quantities.

Work without Interruptions
Automatic self-cleaning function

Small Injection Quantity

Large Injection Quantity



Foamed bitumen is produced by injecting compressed air and water into hot bitumen in a controlled process.

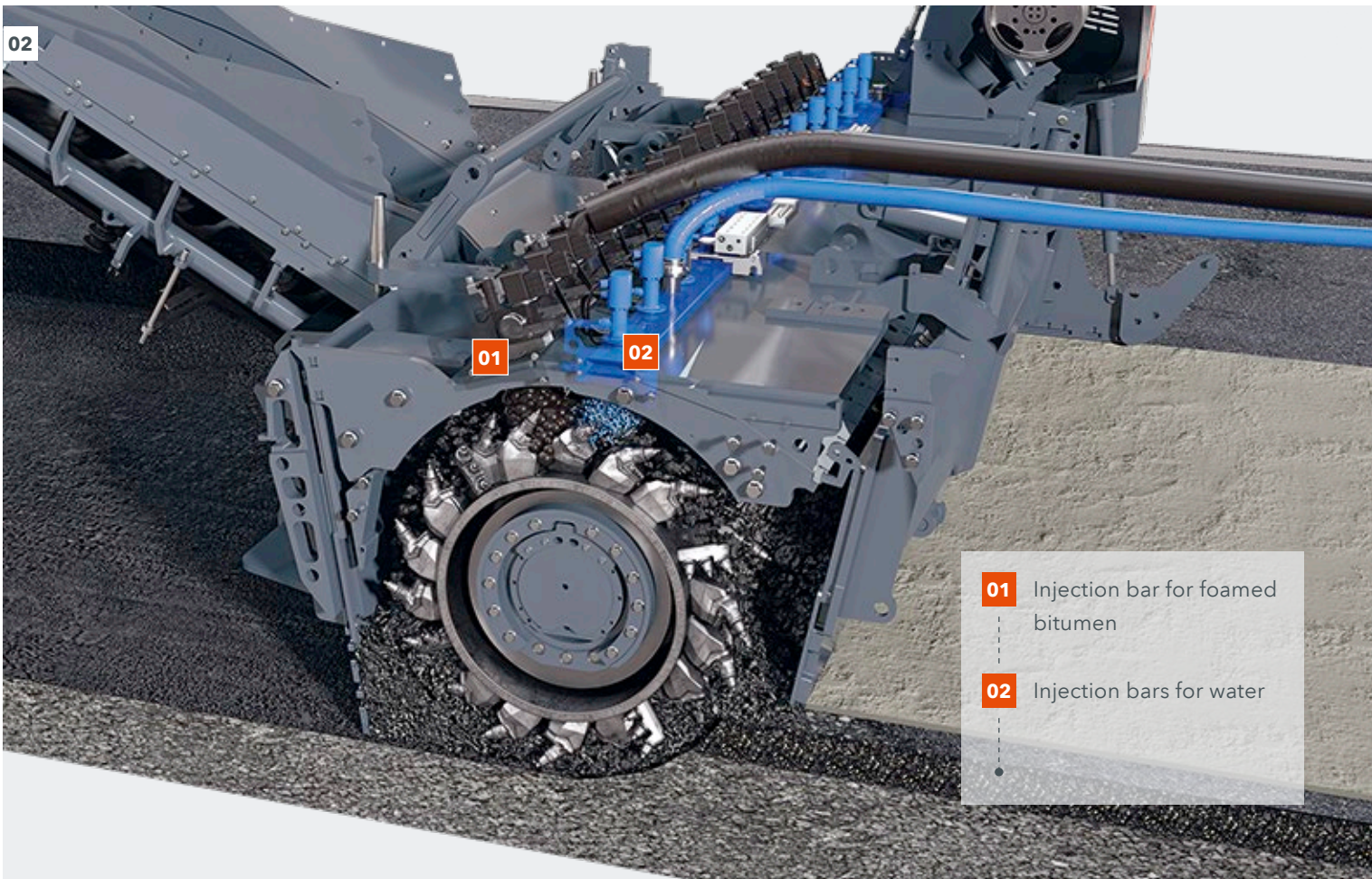

02

01

02

01 Injection bar for foamed bitumen

02 Injection bars for water

EFFECTIVE CUTTING AND MIXING TECHNOLOGY

Perfectly Designed Milling and Mixing Unit

The milling and mixing unit is designed for heavy-duty milling and mixing applications. It is ideally suited for both the down-cut process, which produces the ideal particle gradation and is the preferred method in cold recycling, and the tried-and-tested up-cut process which is used in front-loading milling operations. The side plates, scraper and rotor plate require only minor modifications to be suitable for use in both directions of operation. The large stroke of the machine's height adjustment feature and wide-opening rotor plate permit additional premilled material to be included in the recycling process.

Extremely Hard-Wearing HT22 Quick-Change Toolholder System

The milling and mixing rotors fitted with the HT22 quick-change toolholder system are ideally suited to perform complex recycling and milling operations. The upper parts of the quick-change toolholders can be replaced quickly and effortlessly right on the construction site.

Easy Pick Replacement

The hydraulically operated rotor rotation device, used in combination with the hydraulic pick ejector drift or pneumatic pick driver and ejector drift, facilitates pick replacement - even with the engine switched off. The large stroke of the machine's height adjustment feature and wide-opening rotor plate additionally optimize accessibility and operator comfort.

MCS for Working Widths of 3.2 m, 3.5 m and 3.8 m

To enhance the flexibility of the W 380 CR(i) the **MCS EXTEND** milling and mixing unit can be converted to working widths of 3.2 m, 3.5 m or 3.8 m within a short period of time. This is realized by mounting additional extension elements for the rotor, rotor housing and injection bars.

Reduced Wear

HT22

Extend Your Capabilities

MCS EXTEND for larger working widths



MCS **EXTEND** Milling and Mixing Unit of the W 380 CR(i) With a Working Width of 3.2 m

02

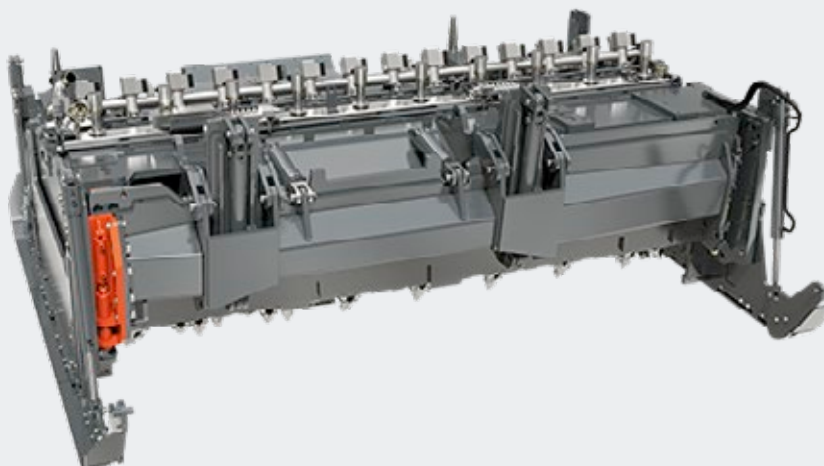

MCS **EXTEND** Milling and Mixing Unit of the W 380 CR(i) With a Working Width of 3.5 m

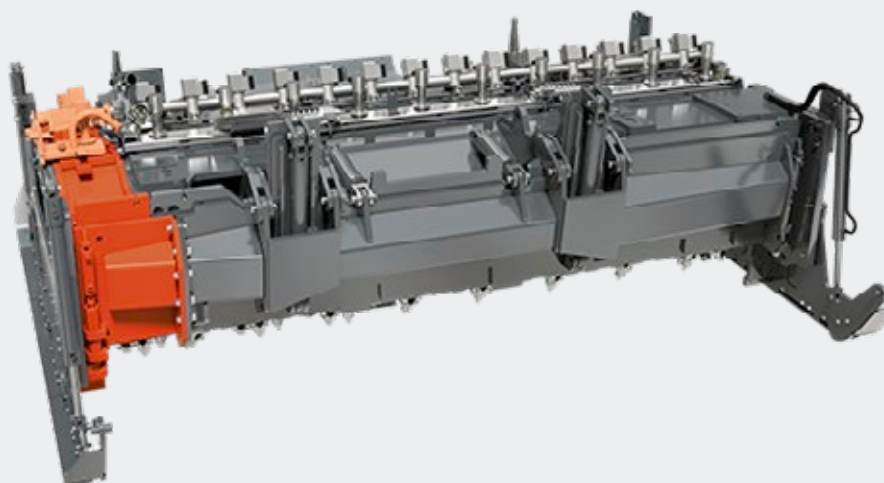

MCS **EXTEND** Milling and Mixing Unit of the W 380 CR(i) With a Working Width of 3.8 m

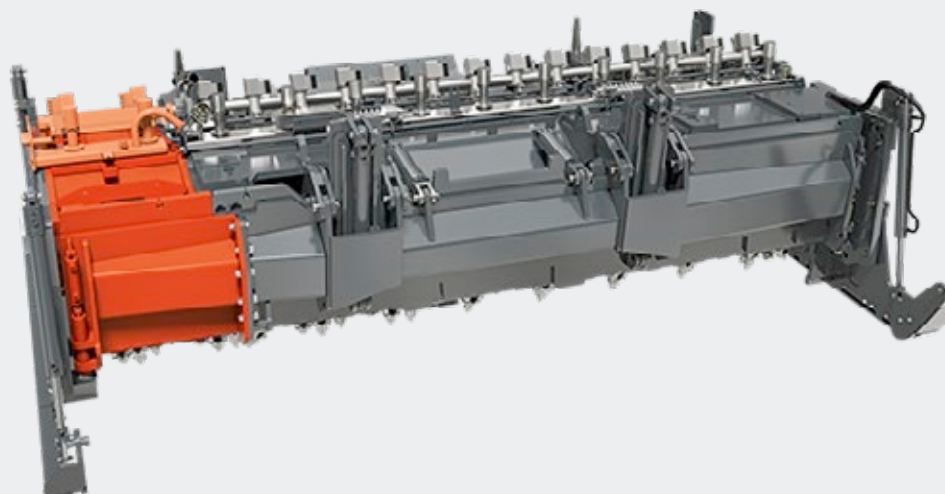

01 The milling and mixing unit is suitable for use in both directions of operation.

02 The MCS **EXTEND** milling and mixing unit of the W 380 CR(i) can be converted to working widths of 3.2 m, 3.5 m or 3.8 m.

COLD RECYCLING WITH HIGH-PERFORMANCE REAR LOADING

Cold Recycling with the W 380 CR(i) in a Single Pass

The W 380 CR(i) cold recycler's mixing capacity of up to 800 t/h enables the production of larger quantities of cold mix. The mix is then transferred to the VÖGELE paver following right behind the recycler via the integrated conveyor system. The powerful paving screed is capable of paving large layer thicknesses and large lane widths in a single machine pass.

High Storage Capacity in the Paver's Material Hopper

During cold recycling with rear loading, the cold recycling mix is conveyed to the paver's material hopper via the discharge conveyor. The hopper acts as an ideal material buffer with ample storage capacity, making it easy to equalize any ground irregularities.

01



A Example of an application with the W 380 CR(i)

Cold recycling with a discharge conveyor and a paver
(lateral pre-milling enables variable working widths)



01 The W 380 CR(i) recycles road pavements at a mixing capacity of up to 800 t/h.

COLD RECYCLING WITH LATERAL PRE-MILLING



01

Material Guide Plate System for Variable Paving Widths

Granulated material produced in milling operations previously performed by small or compact milling machines is picked up via the adjustable material guide plate system installed at the front of the machine and added to the mixing process. Thanks to the increased mixing capacity in combination with rear loading and a VÖGELE paver following behind the machine, it is also possible to rehabilitate varying pavement widths in a single pass.

The two guide plates of the material guide plate system can be independently adjusted mechanically to the width of the previously produced material windrow. Height and contact pressure are adjusted hydraulically.

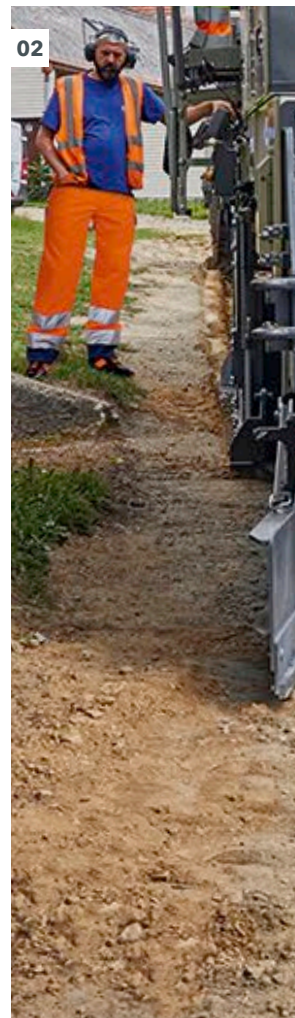

02

01 - 02 The recycler picks up the granulated material produced in a previous milling operation via the integrated guide plate system to recycle the road pavement across the full width.

B Example of an application with the W 240 CR(i) / W 380 CR(i)

Lateral pre-milling possible and cold recycling with a W 240 CR(i) / W 380 CR(i) and a paver



OTHER APPLICATIONS

In addition to the high-performance recycling of road pavements as the main application, the cold recycler is also capable of milling, homogenizing or granulating asphalt pavements. This maximizes machine utilization.

Milling:

The cold recycler can also be operated as an efficient high-performance large milling machine using the up-cut process. An ultra-strong engine and high conveying capacity make it the ideal candidate for milling jobs requiring extremely high outputs, such as the reclamation of asphalt pavements at full depth. High advance rates and milling depths guarantee the quick completion of large construction projects on motorways or airport runways.

Homogenizing:

The machine is also capable of homogenizing, for example, asphalt layers with an underlying gravel layer. The mixture is deposited and subsequently overlaid with new bound layers.

Granulating:

The powerful cold recycler granulates the damaged asphalt layers to specification without adding any binders to the process. The homogeneous construction material granulate can be optimally compacted and ranks among the high-quality base-layer materials in unbound construction.

01



- 01** The machine can be operated as an efficient high-performance large milling machine using the up-cut process.
- 02** The cold recycler's range of applications also includes homogenization and granulation.
- 03** The W 240 CR(i) can be easily transported as a single unit.

02



Ease of Transport

The compact W 240 CR(i) can be easily transported as a single unit on a low-loader truck. A major advantage when transporting the W 240 CR(i) is that all components can remain mounted on the machine.

Thanks to the intelligent design concept, the large milling and mixing unit of the W 380 CR(i) can be mounted or removed quickly and placed on an assembly dolly in preparation for transportation.

03







Cold In-place Recycling (CIR) and Full Depth Reclamation (FDR): the CR series machines are used as part of a paving train for the economical cold in-place recycling of road pavements in a single pass adding cement, emulsion or foamed bitumen, featuring a mixing capacity of up to 800 t/h. The high-performance W 240 CR(i) with rear loading and a working width of 2,350 mm is ideal for the rehabilitation of road pavements on construction sites with limited space and can also be transported easily from job to job as a single unit.

The high-performance W 380 CR(i) with rear loading and a working width of 3,800 mm is used for rehabilitating full, very wide road surfaces at an extremely high daily productivity.

TECHNICAL SPECIFICATIONS	W 240 CR	W 240 CRi
Milling and Mixing Rotor		
Working width	2,350 mm	
Working depth ¹⁾	0 to 350 mm	
Drum diameter with tools	1,140 mm	
Rotor speed at maximum operating speed	108 rpm	100 rpm
Engine		
Manufacturer	Caterpillar	
Type	C27 ATAAC	
Cooling	Water	
Number of cylinders	12	
Power	at 2,100 rpm: 708 kW / 950 HP / 963 PS	at 2,000 rpm: 653 kW / 875 HP / 888 PS
Maximum power	at 1,800 rpm: 708 kW / 950 HP / 963 PS	at 1,800 rpm: 775 kW / 1.038 HP / 1.054 PS
Displacement	27.2 l	27.2 l
Fuel consumption, full load	187 l/h	195 l/h
Fuel consumption, field mix	75 l/h	80 l/h
Exhaust emission standard	no EU regulation / US EPA Tier 2	EU Stage 5 / US EPA Tier 4f
Electrical System		
Voltage supply	24 V	
Filling Capacities		
Fuel	1,400 l	
Hydraulic fluid	350 l	
Water	4,000 l	
Driving Performance		
Operating and travel speed	0 to 88 m/min (0 to 5.3 km/h)	
Track Units		
Track units, front and rear (L x W x H)	2,250 x 370 x 790 mm	
Conveyor System		
Belt width of primary conveyor	1,100 mm	
Belt width of discharge conveyor	1,100 mm	
Theoretical capacity of discharge conveyor	668 m ³ /h	

¹⁾ The maximum working depth may deviate from the value indicated due to tolerances and wear.



W 380 CR		W 380 CRi	
		3,800 mm	
		0 to 350 mm	
		1,140 mm	
108 rpm		100 rpm	
		Caterpillar	
		C27 ATAAC	
		Water	
		12	
at 2,100 rpm: 708 kW / 950 HP / 963 PS		at 2,000 rpm: 653 kW / 875 HP / 888 PS	
at 1,800 rpm: 708 kW / 950 HP / 963 PS		at 1,800 rpm: 775 kW / 1,038 HP / 1,054 PS	
27.2 l		27.2 l	
187 l/h		195 l/h	
75 l/h		80 l/h	
no EU regulation / US EPA Tier 2		EU Stage 5 / US EPA Tier 4f	
		24 V	
		1,400 l	
		350 l	
		4,000 l	
		0 to 88 m/min (0 to 5.3 km/h)	
		2,250 x 370 x 790 mm	
		1,100 mm	
		1,100 mm	
		668 m³/h	

TECHNICAL SPECIFICATIONS	W 240 CR	W 240 CR i
Weight of Basic Machine		
Empty weight of machine in standard design excluding operating fluids	45,800 kg	
Operating weight, CE ²⁾	48,500 kg	
Maximum operating weight (full tanks, full range of equipment)	54,400 kg	
Weights of Operating Fluids		
Filling of water tank	4,000 kg	
Filling of fuel tank (0.83 kg/l)	1,150 kg	
Additional Add-On Weights		
Operator and tools		
> Operator	75 kg	
> 5 pick containers	125 kg	
Injection systems in lieu of standard		
> Model without spraying system: Injection openings in rotor housing closed	-400 kg	
> Double spraying system: with VARIO spraying bars for water (800 l/min) and bitumen emulsion or foamed bitumen (500 kg/min)	840 kg	
Optional additional equipment		
> Material guide plates on the front track units	900 kg	
> Canopy	500 kg	
> Minus discharge conveyor	-2,850 kg	
> VCS extraction system	250 kg	
Transport Weights of Single Components		
Empty weight of machine in standard design excluding milling and mixing unit	-	
Milling and mixing unit on transport carriage (L x W x H : 4,750 x 2,900 x 2,400 mm)	-	
Transport carriage for milling and mixing unit	-	

²⁾ Machine in standard design, half-full water tank, half-full fuel tank, operator, on-board tools, excluding optional equipment features

	W 380 CR	W 380 CR i
		50,300 kg
		53,000 kg
		58,900 kg
		4,000 kg
		1,150 kg
		75 kg
		125 kg
		-400 kg
		900 kg
		900 kg
		500 kg
		-
		250 kg
		35,100 kg
		16,500 kg
		1,300 kg

SIDE VIEW / TOP VIEW W 240 CR(i)

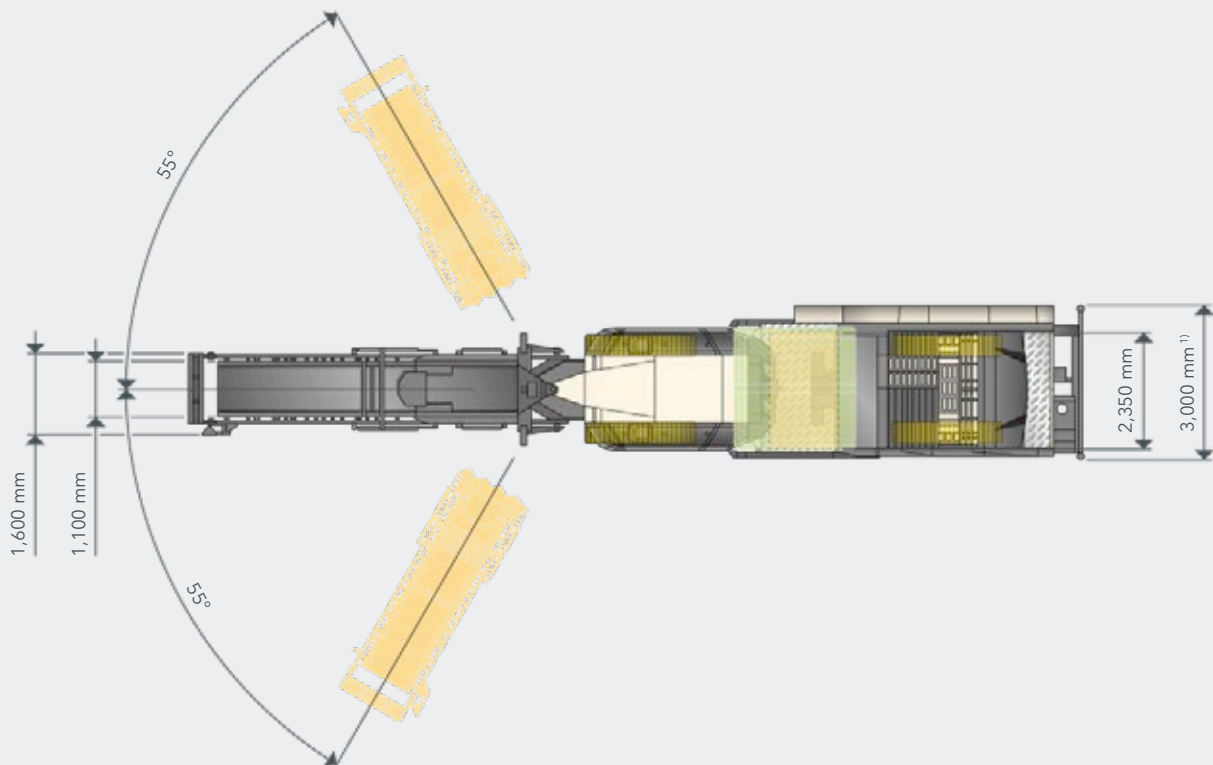
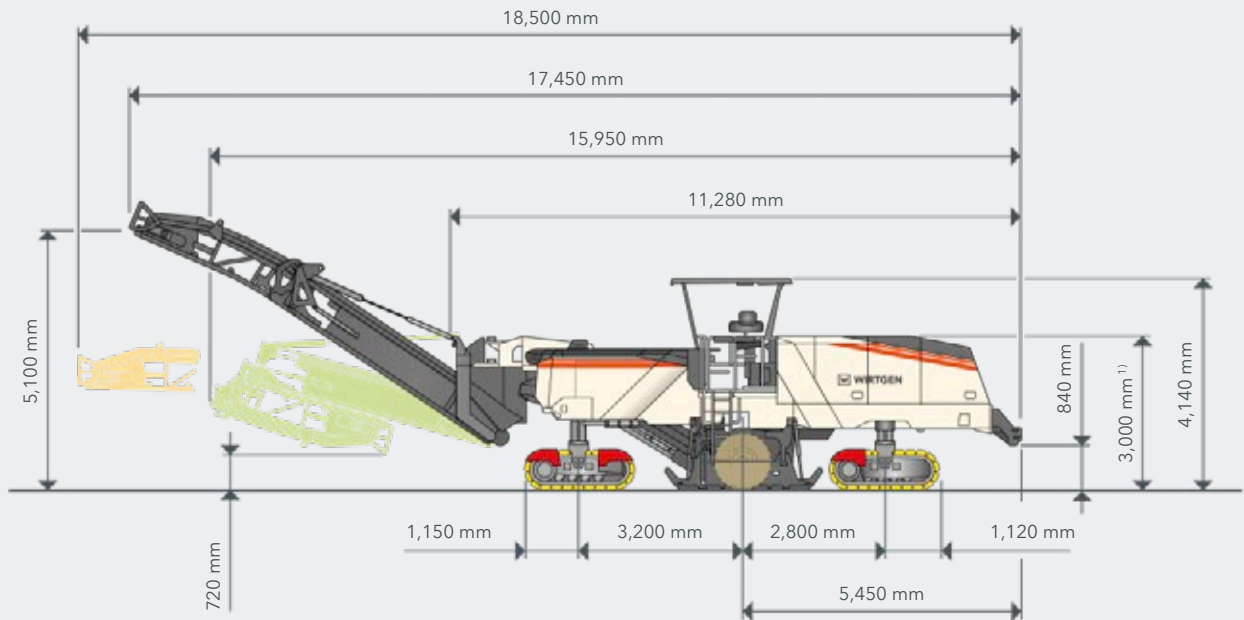

¹⁾ Dimensions for low-loader transport

REAR VIEW W 240 CR(i)

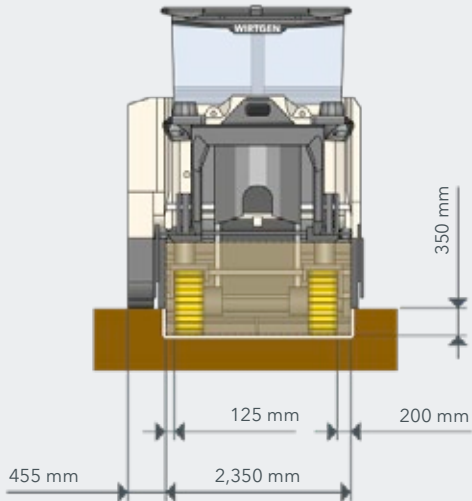

GROUND CLEARANCE W 240 CR(i)

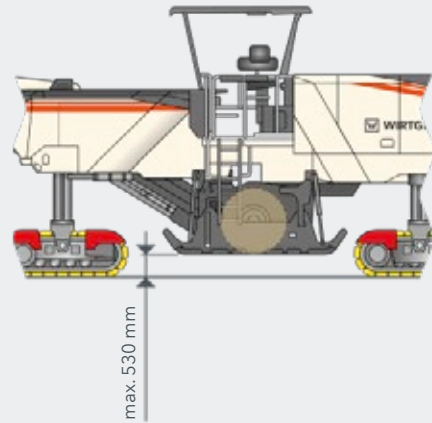

OPERATING RADIUS W 240 CR(i)

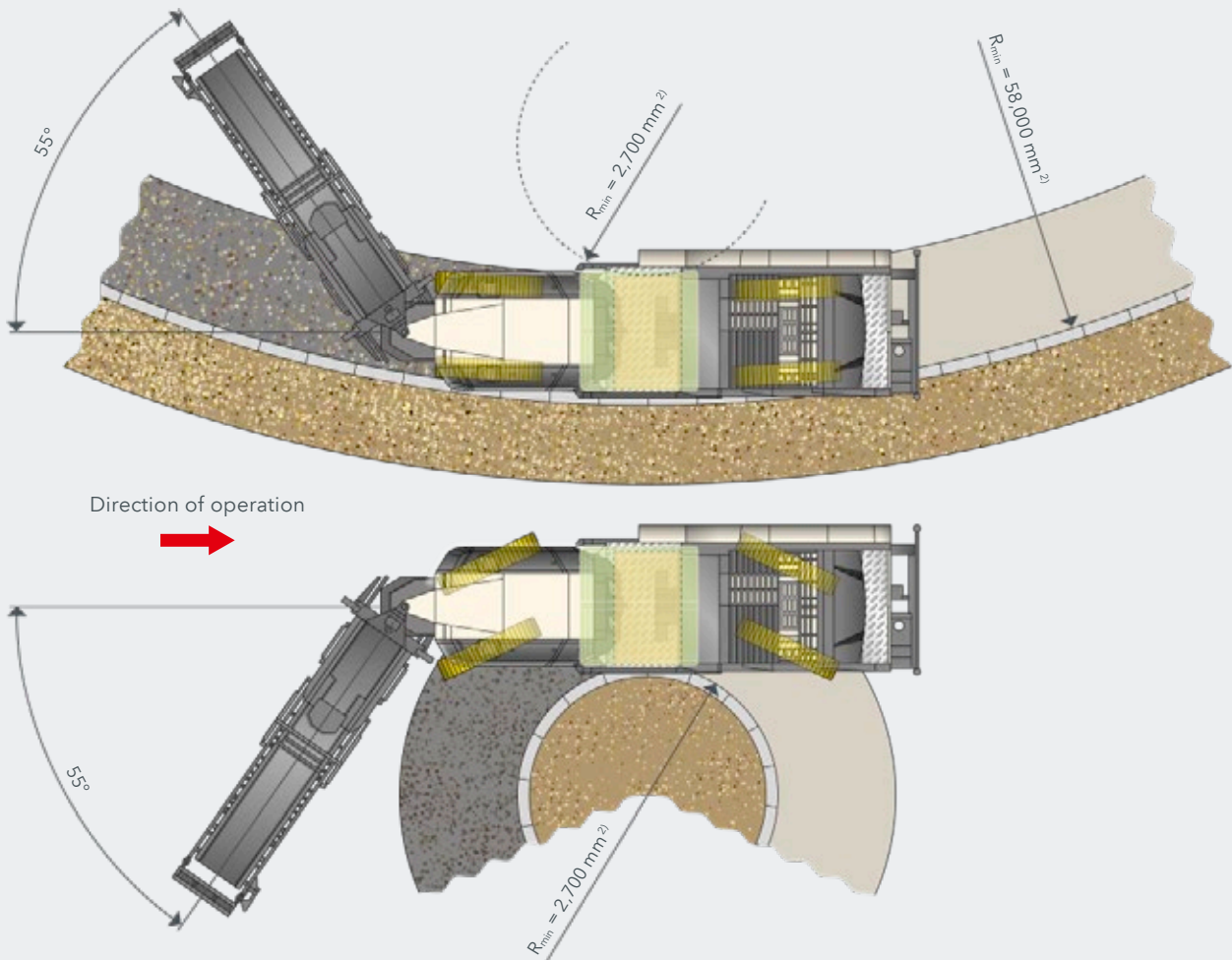

²⁾ Small operating radii may lead to increased wear of the milling and mixing rotor.

SIDE VIEW / TOP VIEW W 380 CR(i)

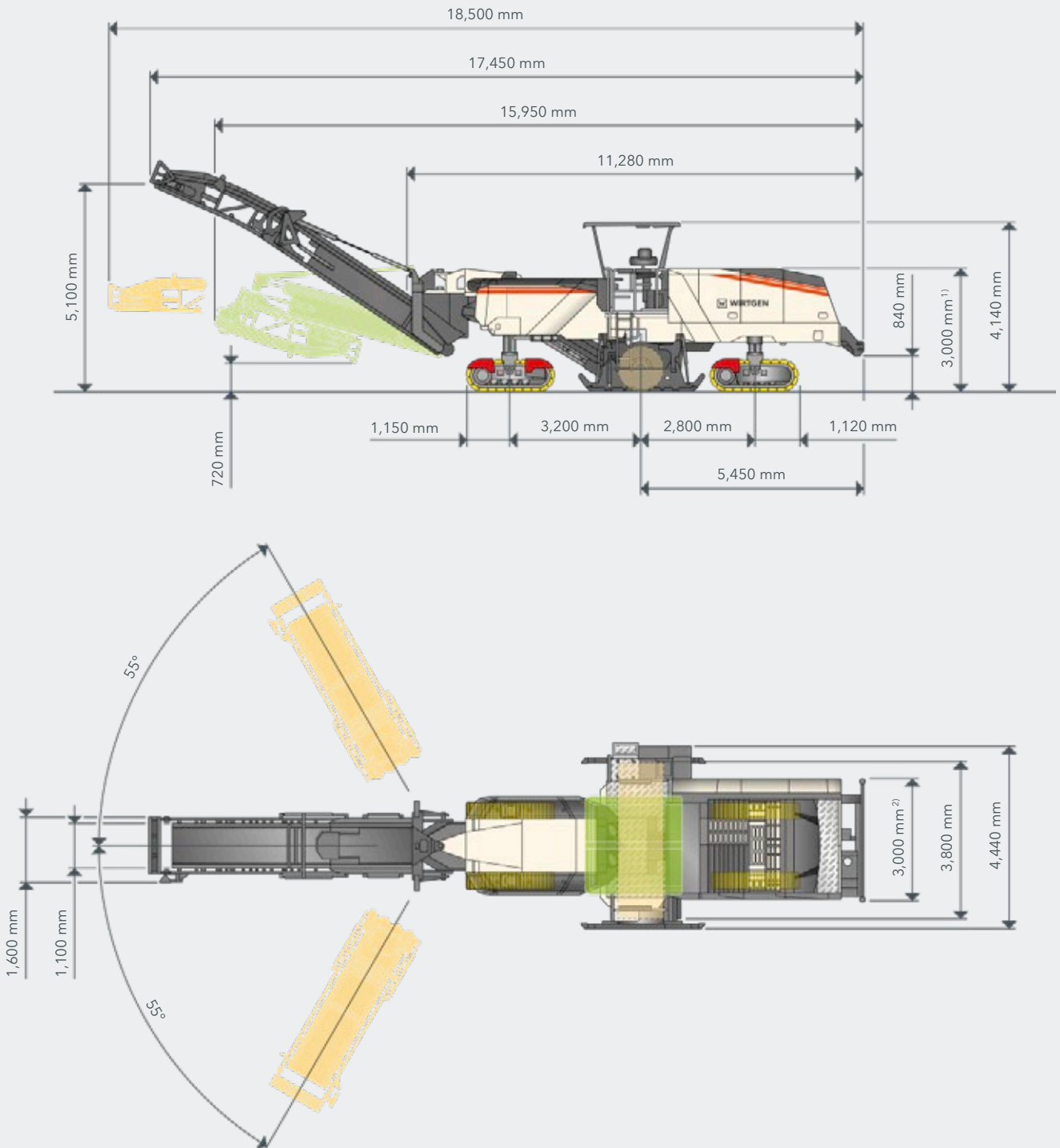

¹⁾ Dimensions for low-loader transport

²⁾ Transport width excluding milling and mixing unit

REAR VIEW W 380 CR(i)

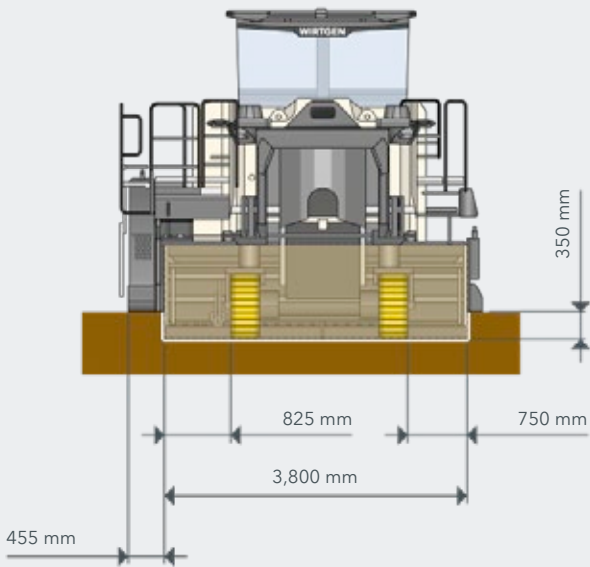

GROUND CLEARANCE W 380 CR(i)

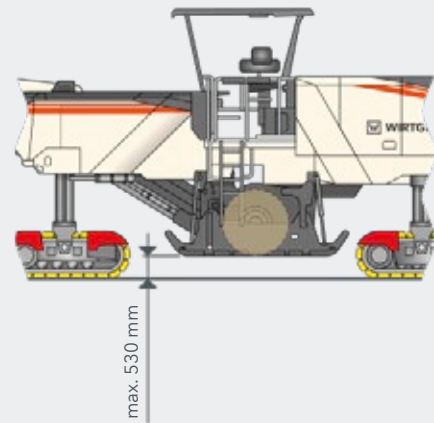

OPERATING RADIUS W 380 CR(i)

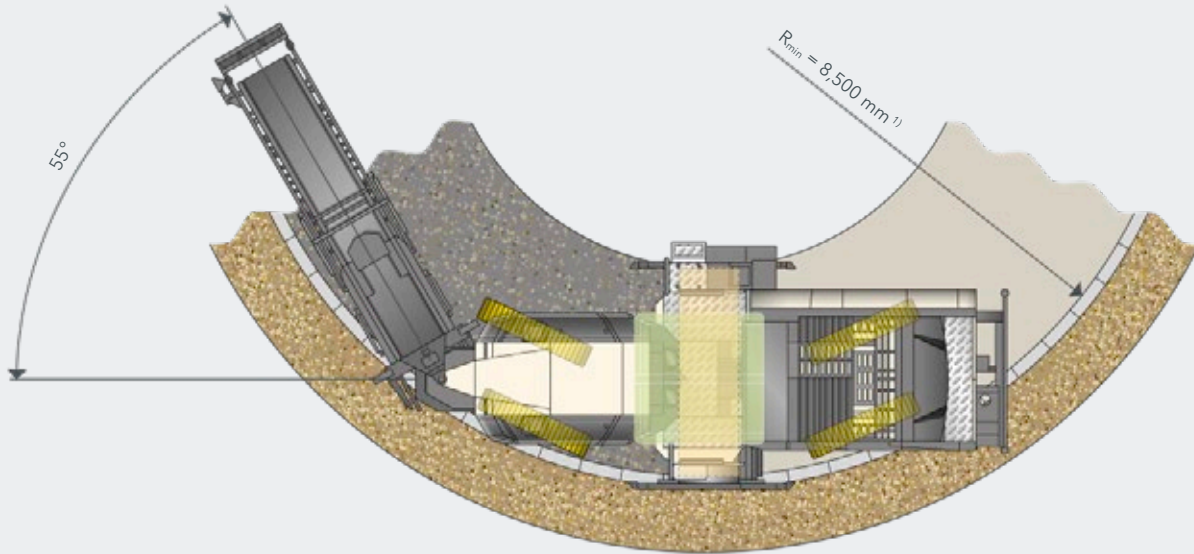

Direction of operation

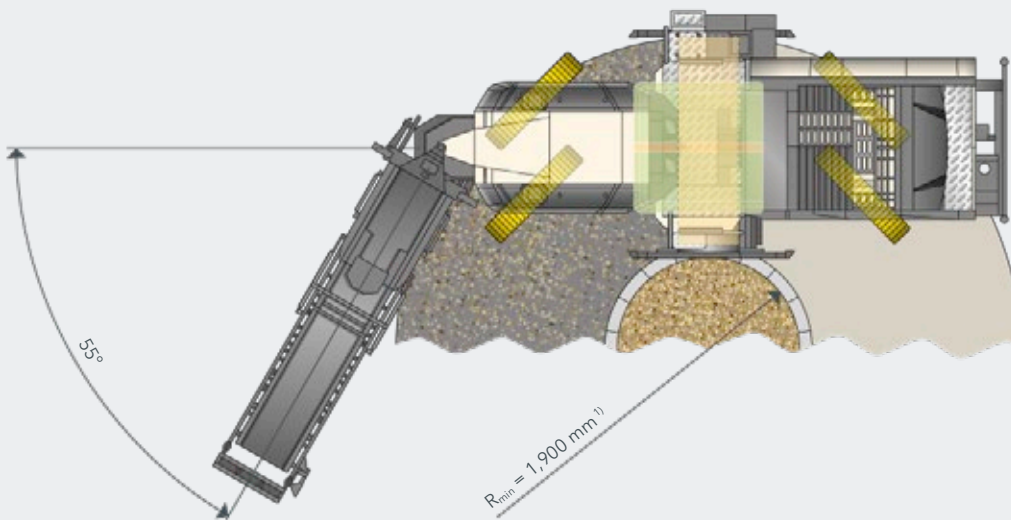

¹⁾ Small operating radii may lead to increased wear of the milling and mixing rotor

TRANSPORT DIMENSIONS

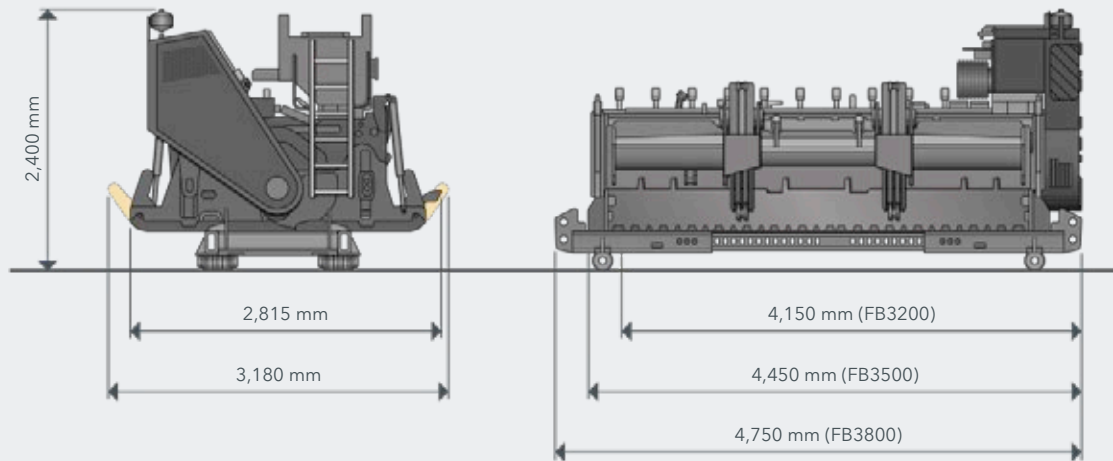

Milling and mixing unit FB3800 including transport carriage

STANDARD EQUIPMENT	W 240 CR(i)	W 380 CR(i)
Basic Machine		
> Base machine with engine	■	■
> The machine can be used as a cold recycler in rear-loading mode or as a cold milling machine in front-loading mode	■	■
> Soundproof lining of engine compartment	■	■
> Diesel engine power controller for optimum milling and mixing results	■	■
> Load limit controller for optimum operation in down-cut mode	■	■
> Engine cooling system with temperature-controlled fan speed	■	■
> Machine frame providing optimum visibility for rear- and front-loading operations	■	■
> Air compressor system, max. 8 bar	■	■
> Battery-operated hydraulic unit	■	■
> Mechanical drum drive via high-performance V-belts with automatic belt tensioner	■	■
> Milling drum gearbox for down-cut operation in rear-loading mode	□	□
Milling and Mixing Unit		
> Three electrically selectable milling drum speeds	■	■
> Quick and easy conversion from rear-loading to front-loading operation	■	■
> Water spray system with automatic on/off function including two spray bars in the milling and mixing unit	■	■
> Hydraulically movable and adjustable front drum plate with exchangeable carbide elements	■	■
> Rear drum sealing plate with hydraulic conveyor lifting feature and exchangeable carbide elements	■	■
> Hydraulically lifting side plates, optimized for both directions of operation	■	■
> Milling drum housing FB2350	■	—
> Milling drum housing FB3800	—	□
Milling and Mixing Rotor		
> Milling and Mixing Rotor FB2350 HT22 PLUS LA15 D20 with 198 picks	■	—
> Milling and Mixing Rotor FB3800 HT22 PLUS LA15 D20 with 294 picks	—	□
> Power multiplier for defined bolt tightening when changing the milling drum unit	—	■
Loading of the Milled and Mixed Material		
> Conveyor system with manually or automatically adjustable conveying speed	■	■
> Two slewing speeds on the hydraulically foldable discharge conveyor	■	■
> Water sprinkling system in the primary conveyor	■	■
> Primary conveyor: 1,100 mm discharge conveyor belt width, material depressor with scraper function	■	■
> Discharge conveyor belt: 1,100 mm belt width, slewing angle +/- 55°	□	■
Injection System / Addition of Binders		
> Single spraying system (FB2350) with VARIO spraying bars for water (800 l/min)	□	—
> Single spraying system (FB3800) with VARIO spraying bars for water (800 l/min)	—	□
> Model without extension elements for spraying system	—	□

STANDARD EQUIPMENT	W 240 CR (i)	W 380 CR (i)
Machine Control and Leveling System		
> Multifunctional color control screen displaying important machine operating conditions	■	■
> Extensive machine diagnostics in the machine display	■	■
> Automated features to reduce the machine operator's workload	■	■
> Four exterior control panels for operating functions performed by the ground crew	■	■
> LEVEL PRO leveling system for milling depth control, including one control screen and one each electrical height sensor in the hydraulic cylinders on the side plates, right and left	■	■
Operator's Platform		
> Fully anti-vibration mounted operator's platform	■	■
> Convenient access to the operator's platform, left and right	■	■
> Fold-out extension of operator's platform, right	■	■
> Large storage compartment and stand-up seats, left and right	■	■
> Two mirrors at the front, two mirrors at the rear of the machine	■	■
> Walk-through operator's platform with one each control panel, right and left	■	■
> The control panels can be adjusted in height, rotated and positioned in line with ergonomic principles and the machine's direction of operation	■	■
> Lockable control panel covers	■	■
> Camera at the front with two screens, right and left	■	■
Track Unit and Height Adjustment		
> PTS - automatic alignment of the machine parallel to the pavement surface	■	■
> ISC - intelligent track speed control including hydraulic four-track drive	■	■
> Fourfold full-floating axle for high machine stability	■	■
> High ground clearance for improved access when replacing picks or removing the milling and mixing unit	■	■
> Four-track steering system offering the following steering modes in both directions of operation: crab, cornering or straight-ahead mode	■	■
> Extremely wear-resistant, two-part EPS Plus polyurethane track pads	■	■
Miscellaneous		
> Water filling front - without filling pump	■	■
> Washdown system with hose reel and cleaning gun	■	■
> Comprehensive LED lighting system, 24 V	■	■
> "Welcome-and-Go-Home-Light" feature including LED lighting in the area of the operator's platform and access	■	■
> Large tool kit in lockable tool box	■	■
> EMERGENCY STOP switches in appropriate positions on the machine	■	■
> Pre-fitting for installing the WITOS FleetView control unit "WIRTGEN Road Technologies Telematics and on-site Solutions" (WITOS) is the intelligent telematics system of the WIRTGEN Road Technologies for efficient fleet and service management worldwide	■	■
> Water tank filling from rear of machine with hydraulic filling pump	□	□
> Standard painting in RAL 9001 (cream)	□	□
> WITOS - professional telematics solution for machine operation and service optimization	□	□

■ = Standard equipment

□ = Standard equipment, can be replaced with optional equipment if desired

□ = Optional equipment

OPTIONAL EQUIPMENT	W 240 CR(i)	W 380 CR(i)
Basic Machine		
> Milling drum gearbox for up-cut operation in rear-loading mode	<input type="checkbox"/>	<input type="checkbox"/>
Milling and Mixing Unit		
> Milling drum housing FB3200 MCS EXTEND	—	<input type="checkbox"/>
> Milling drum housing FB3500 MCS EXTEND	—	<input type="checkbox"/>
> Milling drum housing FB3800 MCS EXTEND	—	<input type="checkbox"/>
> Ancillary parts for milling drum housing with extension to FB3200 MCS EXTEND	—	<input type="checkbox"/>
> Ancillary parts for milling drum housing with widening to FB3500 MCS EXTEND	—	<input type="checkbox"/>
> Ancillary parts for milling drum housing with widening to FB3800 MCS EXTEND	—	<input type="checkbox"/>
Milling and Mixing Rotor		
> MCS EXTEND milling and mixing rotor, FB3200 HT22 PLUS LA15 D20, multi-part, with 239 picks	—	<input type="checkbox"/>
> MCS EXTEND milling and mixing rotor, FB3500 HT22 PLUS LA15 D20, multi-part, with 258 picks	—	<input type="checkbox"/>
> MCS EXTEND milling and mixing rotor, FB3800 HT22 PLUS LA15 D20, multi-part, with 277 picks	—	<input type="checkbox"/>
> Transport frame for additional MCS milling units MCS EXTEND	—	<input type="checkbox"/>
> Assembly aid for additional MCS milling units MCS EXTEND	—	<input type="checkbox"/>
Loading of the Milled and Mixed Material		
> Model without discharge conveyor	<input type="checkbox"/>	—
> VCS extraction system	<input type="checkbox"/>	<input type="checkbox"/>
> Hydraulically adjustable deflector plate on the discharge conveyor	<input type="checkbox"/>	<input type="checkbox"/>
> Supports for discharge conveyor	<input type="checkbox"/>	<input type="checkbox"/>
Injection System / Addition of Binders		
> Double spraying system (FB2350) with VARIO spraying bars for water (800 l/min) and bitumen emulsion or foamed bitumen (500 kg/min)	<input type="checkbox"/>	—
> Double spraying system (FB3800) with VARIO spraying bars for water (800 l/min) and bitumen emulsion or foamed bitumen (500 kg/min)	—	<input type="checkbox"/>
> Model without spraying system	<input type="checkbox"/>	<input type="checkbox"/>
Injection System / Addition of Binders (MCS EXTEND only)		
> Single spraying system (MCS EXTEND) with VARIO spraying bar for water (800 l/min)	—	<input type="checkbox"/>
> Double spraying system (MCS EXTEND) with VARIO spraying bars for water (800 l/min) and bitumen emulsion or foamed bitumen (500 kg/min)	—	<input type="checkbox"/>
> Model without spraying system MCS EXTEND	—	<input type="checkbox"/>
> Extension of single spraying system for water to FB3500 MCS EXTEND	—	<input type="checkbox"/>
> Extension of double spraying system for water and bitumen emulsion or foamed bitumen to FB3500 MCS EXTEND	—	<input type="checkbox"/>
> Extension without spraying system FB3500 MCS EXTEND	—	<input type="checkbox"/>
> Extension of single spraying system for water to FB3800 MCS EXTEND	—	<input type="checkbox"/>
> Extension of double spraying system for water and bitumen emulsion or foamed bitumen to FB3800 MCS EXTEND	—	<input type="checkbox"/>
> Extension without spraying system FB3800 MCS EXTEND	—	<input type="checkbox"/>

OPTIONAL EQUIPMENT	W 240 CR (i)	W 380 CR (i)
Machine Control and Leveling System		
> Ultrasonic sensor for wire or ground scanning	<input type="checkbox"/>	<input type="checkbox"/>
> Additional LEVEL PRO control screen	<input type="checkbox"/>	<input type="checkbox"/>
> Pre-fitting for multiplex system comprising 4 sensors sockets	<input type="checkbox"/>	<input type="checkbox"/>
> 3-way multiplex system, right, including 2 ultrasonic sensors	<input type="checkbox"/>	<input type="checkbox"/>
> 3-way multiplex system, right and left, including 4 ultrasonic sensors	<input type="checkbox"/>	<input type="checkbox"/>
> Level control 3D leveling pre-equipment	<input type="checkbox"/>	<input type="checkbox"/>
> Cross-slope sensor for machine	<input type="checkbox"/>	<input type="checkbox"/>
Operator's Platform		
> Weather canopy, electro-hydraulic fold-down feature	<input type="checkbox"/>	<input type="checkbox"/>
Miscellaneous		
> Water tank filling from rear of machine with hydraulic filling pump	<input type="checkbox"/>	<input type="checkbox"/>
> Painting in one special color (RAL)	<input type="checkbox"/>	<input type="checkbox"/>
> Painting in two special colors (RAL)	<input type="checkbox"/>	<input type="checkbox"/>
> Model without WITOS	<input type="checkbox"/>	<input type="checkbox"/>
> USB interface for retrieving the job data	<input type="checkbox"/>	<input type="checkbox"/>
> Transport carriage for milling drum units from FB2200 to FB4400	—	<input type="checkbox"/>
> High-pressure water cleaner, 190 bar, 15 l/min	<input type="checkbox"/>	<input type="checkbox"/>
> Guide plates on the front track units to guide previously deposited material	<input type="checkbox"/>	<input type="checkbox"/>
> Milling drum rotation device for the milling and mixing units FB3200 - FB3800	<input type="checkbox"/>	—
> Pneumatic hammer with pick extractor/insertor	—	<input type="checkbox"/>
> Hydraulic pick ejector	<input type="checkbox"/>	<input type="checkbox"/>
> Diesel tank filling pump with 5.00 m suction hose	<input type="checkbox"/>	<input type="checkbox"/>
> Wiggins fast-fill system for diesel refuelling	<input type="checkbox"/>	<input type="checkbox"/>
> Additional camera on the discharge conveyor	<input type="checkbox"/>	<input type="checkbox"/>
> Additional monitor system including 5 cameras and monitor	<input type="checkbox"/>	<input type="checkbox"/>
> Pre-fitting for two LED lighting balloons	<input type="checkbox"/>	<input type="checkbox"/>
> LED lighting balloon, 24 volt	<input type="checkbox"/>	<input type="checkbox"/>
> 3" hot bitumen suction hose, 4,000 LG - tanker connection	<input type="checkbox"/>	<input type="checkbox"/>
> 3" water or emulsion suction hose, 5,000 LG - tanker connection	<input type="checkbox"/>	<input type="checkbox"/>
> Support arm for holding the push bar and feed lines whilst changing tankers	<input type="checkbox"/>	<input type="checkbox"/>
> Additional bitumen filter with cleaning housing	<input type="checkbox"/>	<input type="checkbox"/>
> Additional bitumen filter with cleaning housing	<input type="checkbox"/>	<input type="checkbox"/>

■ = Standard equipment

■ = Standard equipment, can be replaced with optional equipment if desired

□ = Optional equipment

**WIRTGEN GmbH**

Reinhard-Wirtgen-Str. 2
53578 Windhagen
Germany

T: +49 2645 131-0
F: +49 2645 131-392
M: info@wirtgen.com

 www.wirtgen.de



For further information, please scan the code.