

Mobile cone crusher

MOBICONE MCO 90(i) EVO2



A LONG HERITAGE OF EXPERTISE

Efficient crushing and screening plants.

For the past 100 years, KLEEMANN GmbH has been developing and manufacturing machines and plants for the natural stone and recycling industries.

High levels of performance and innovative details, simple handling and maximum safety for the operator – this is what KLEEMANN crushing and screening plants stand for.

THE KLEEMANN PRODUCT RANGE

MOBICAT

Mobile jaw crushers

MOBIREX

Mobile impact crushers

MOBICONE

Mobile cone crushers

MOBISCREEN

Mobile screening plants

MOBIBELT

Mobile stackers

Over 100 years of
tradition

A WIRTGEN GROUP Company
An internationally active group of companies



With more than 200
subsidiaries and dealers in Germany and abroad

KLEEMANN

MOBICONE MCO 90(i) EVO2

The team player in hard stone.

Top product quality is always expected from a cone crusher. And this is exactly what the MOBICONE MCO 90(i) EVO2 delivers together with a high production capacity.

The MCO 90(i) EVO2 is the perfect supplement to the MOBICAT MC 110(i) EVO 2 jaw crusher. The innovative cone crusher scores with outstanding cost-effectiveness, intelligent control engineering and top product quality.

Cone crushers are used in medium-hard to hard stone mainly in the 2nd or 3rd crushing stage. But cone crushers are also at home in stand-alone applications such as in gravel.

In all applications, the MCO 90(i) EVO2 stands out with its easy operability thanks to SPECTIVE and SPECTIVE CONNECT. Equipped with an intelligent and effective overload system, safety and stable processes can be guaranteed for top product quality even under difficult conditions.

Cost-effectiveness
at its best



Operability at its
most intuitive



An eye on product
quality



MOBICONE
EVO2

THE HIGHLIGHTS

Perfectly equipped.

01 Feeding unit

> Simple sliding mechanism for fast set-up and transport, easy adaptation of the material discharge pattern into the crusher

02 CFS (Continuous Feed System)

> Innovative feed control with CFS (Continuous Feed System) guarantees optimum material flow

03 Crusher unit

> Cone crusher with large stroke for maximum crushing capacity

04 Overload systems

> Effective overload systems protect the crusher

05 Drive

> Efficient and powerful D-DRIVE diesel-direct drive

06 Operating concept

> SPECTIVE intuitive operating concept
> With SPECTIVE CONNECT, important information is available on your smartphone

07 Post screening unit

> High-performance post screening units (single-/double-deck) with optimised surface usage

> Accessibility & safety

> Fast and ergonomic servicing thanks to excellent accessibility to all components

> Transport

> Easy transport thanks to hydraulic functions

> Environmentally friendly solutions

> Reduced dust and noise
> Low fuel consumption



KLEEMANN SUSTAINABILITY describes innovative technologies and solutions which are consistent with the sustainability objectives of the WIRTGEN GROUP.

WELL THOUGHT-OUT FEEDING UNIT

For short set-up times and optimum loading.

up to 270 t/h
Feed capacity

approx. 6.4 m³
Hopper volume

approx. 8.3 m³
Hopper volume with hopper extension



The MOBICONE MCO 90(i) EVO2's feeding unit is compact and equipped with a simple sliding mechanism.

Thanks to the sliding mechanism, the MCO 90(i) EVO2 reaches a compact transport dimension without requiring the disassembly of components - enabling fast set-up and simple transport. The sliding mechanism makes it possible to adapt the material discharge pattern into the crusher, so it can be ideally loaded.

To protect the crusher against metallic material, a metal detector is installed in the standard version of the feeding unit - a magnetic remover is available as an option - an effective measure to increase operational safety and reduce downtimes.

The bolted relief beam with exchangeable wear elements protects the conveyed material and ensures an even distribution of the feed material.

To ensure a long service life, the hopper is a bolted construction made of robust wear-resistant steel. A steep hopper rear wall prevents caking in the feed area. The optional hopper extension increases the hopper volume and remains on the machine during transport. Rear-side loading by a wheel loader can be carried out conveniently via the hydraulically foldable hopper filling aid.

KLEEMANN > PROCESS KNOWLEDGE

High cost-effectiveness and top product quality require homogeneous loading of the cone crusher. How the material is loaded is decisive: to guarantee even distribution of the material, rear-side loading by a wheel loader should be carried out. This can be done conveniently with the hydraulically foldable hopper filling aid.

The material not only distributes itself evenly before it reaches the crusher, but it also forms a material layer that acts as natural wear protection.



CONTINUOUS FEED SYSTEM (CFS)

For a continuous crusher feed.

The stockpile is monitored with the line coupling option

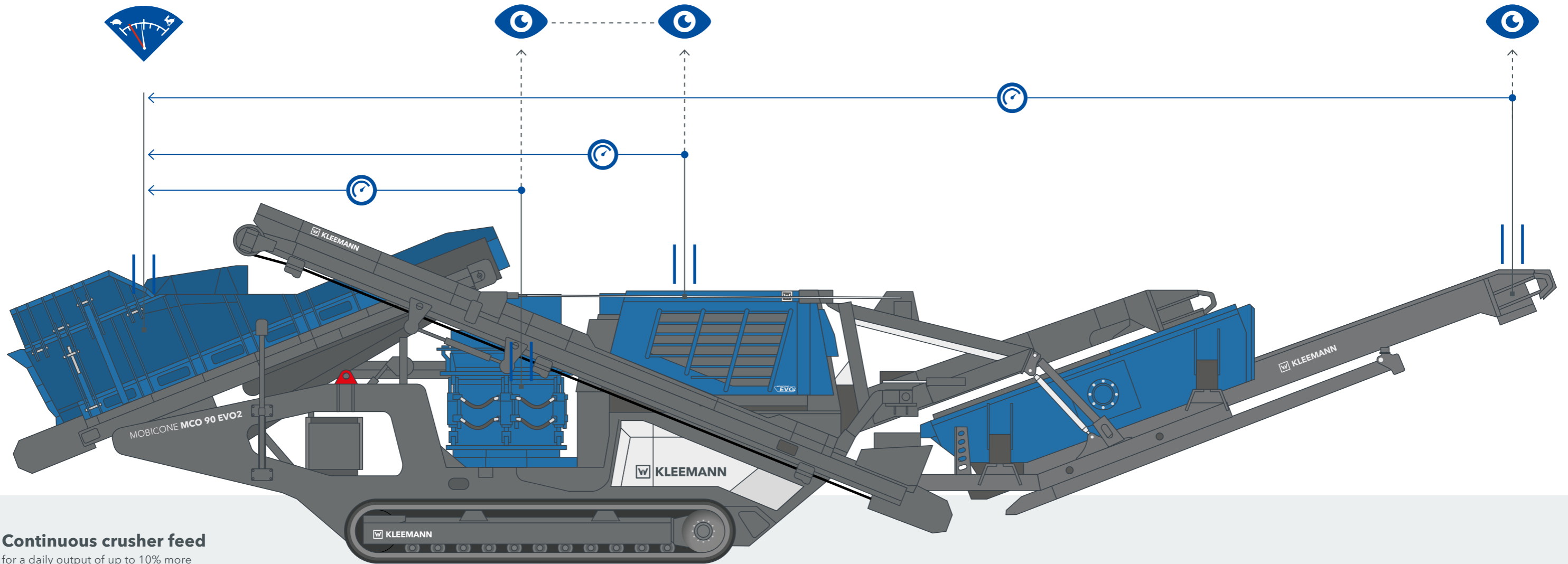

Continuous crusher feed
for a daily output of up to 10% more

Uniform loading is indispensable to ensuring a good product, optimum throughput and low wear.

In order that the crushing chamber is always filled evenly and optimally, the Continuous Feed System (CFS) monitors the crusher level, the utilisation at the crusher drive, the speed of the crusher and the stockpile probe at the crusher discharge conveyor or the fine grain conveyor. Depending on the fill level

of the crusher, the frequency-controlled adjustment of the output of the feeding conveyor is effected. The CFS facilitates the work of the operator because the machine automatically regulates a homogeneous material flow, thus ensuring optimum loading of the crusher.

KLEEMANN > PROCESS KNOWLEDGE

The CFS regulates the belt speed of the feeding unit in good time to achieve an ideal crusher level. The CFS continuously learns and optimises itself in the process.

Result: A high-quality final product with high throughput and low wear.

POWERFUL CRUSHER UNIT

The heart of the machine.

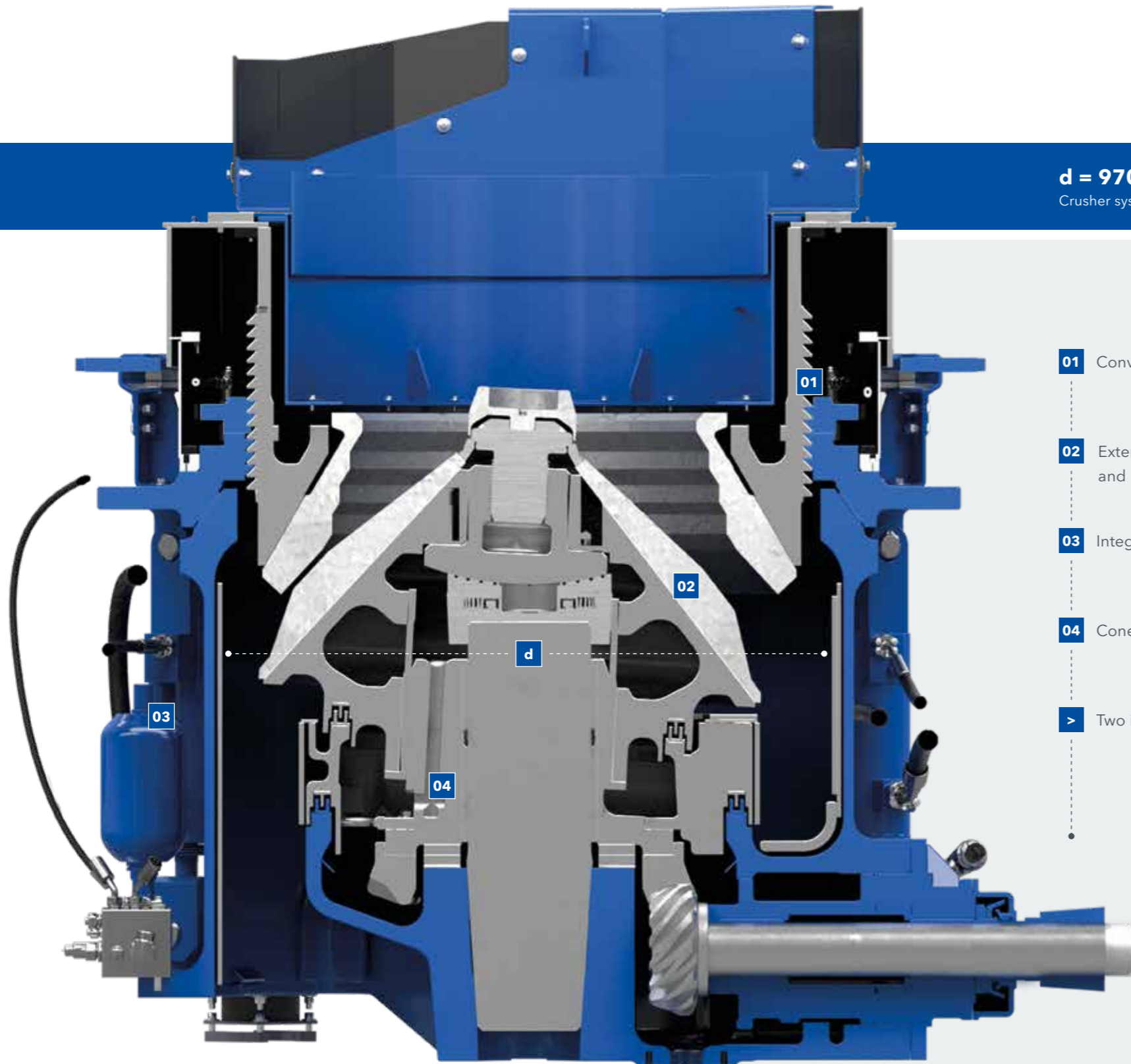

d = 970 mm
Crusher system size

Fully hydraulic
Gap setting

Direct crusher drive
via fluid coupling

- 01 Convenient crusher gap setting
- 02 Extensive selection of mantles and bowl liners
- 03 Integrated overload system
- 04 Cone crusher with large stroke
- > Two inspection hatches

The MCO 90(i) EVO2's crusher unit is the core element of the machine. A large stroke and the 3-arm crusher structure guarantee an impressive crushing capacity and high throughput. The cone crusher, with its different crushing tools, covers gap widths ranging from 6 to 45 mm.



The MOBICONE MCO 90(i) EVO2 mobile cone crusher has a high constant crusher drive power of up to 185 kW and a maximum of up to 250 kW. This enables a continuous crushing process and higher production volume in special applications. Thanks to a short heating-up phase of the lube oil, the plant

is quickly ready for operation. Tool changes are also very easy and take place entirely without sealing compound. The cone crusher, with its different crushing tools, covers gap widths ranging from 6 to 45 mm. Further conversion tasks on the crusher are not required for this wide range of applications.

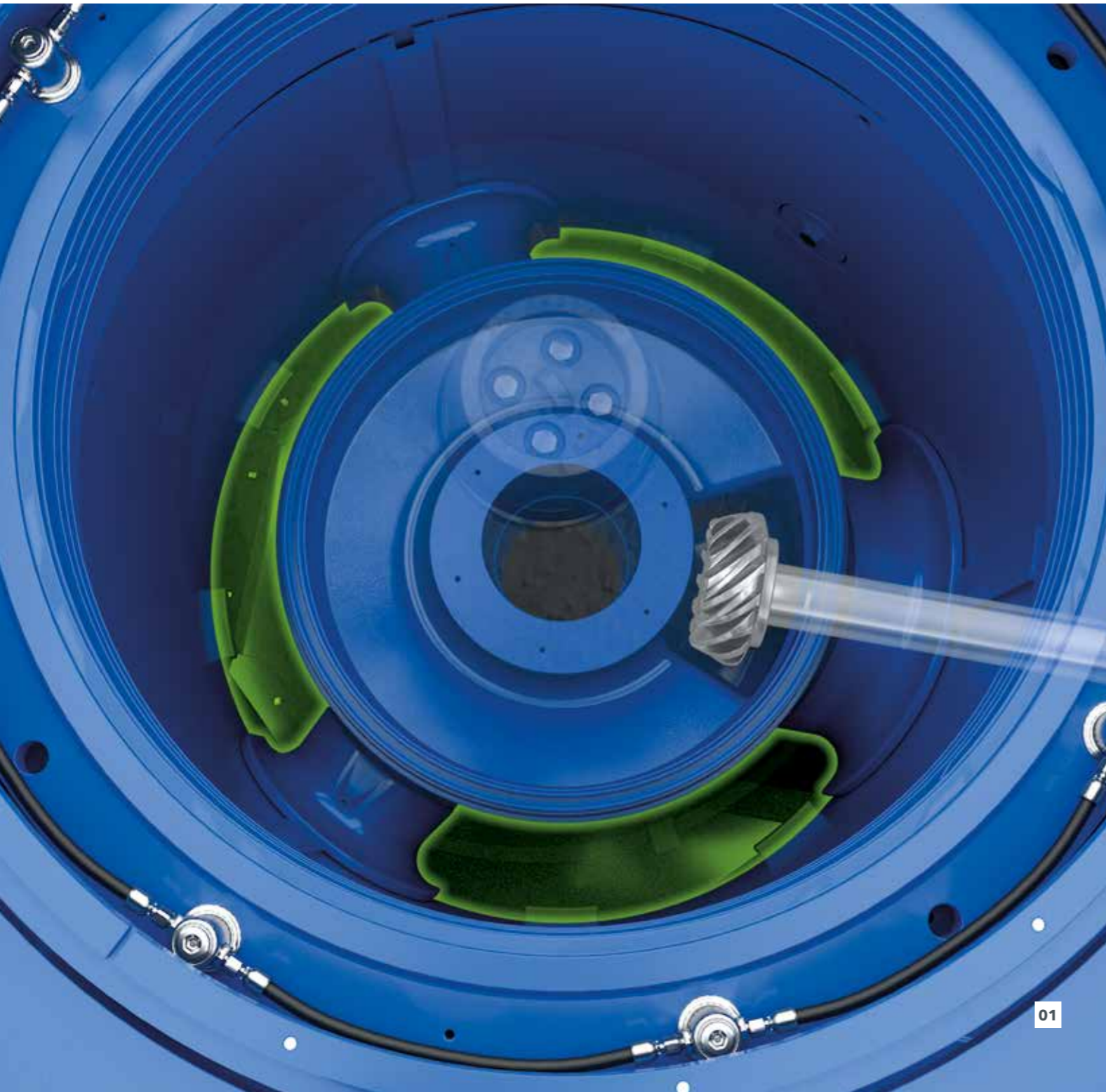

Cone crusher with large stroke

The MCO 90(i) EVO2's crusher unit features a three-arm design and a large stroke for high crushing capacities. Thanks to their stable design and high crusher drive power, a high reduction ratio is possible.

Result: high throughput combined with top reliability

Gap setting

To make adaptations to the desired final grain size or to compensate for wear, a simple gap setting is indispensable. The adjustment of the crushing gap can be carried out conveniently via the touch panel or the radio remote control. This contributes to greater efficiency and productivity.

Rule of thumb: The smaller the CSS, the more closely the process has to be monitored in terms of overloading - the ringbounce detection helps here.



01 Crusher passage 02 Gap setting

KLEEMANN > PROCESS KNOWLEDGE

The correct feed size greatly determines the crushing result, the wear and output of the cone crusher.

If the **feed material is too large**, the feed behaviour is not ideal and the crushing capacity is reduced. Crushing then takes place above the actual crushing zone of the tool, which leads to increased and uneven wear. In the worst case, ringbounce can occur.

If the **feed material is too small**, the power of the crusher is not adequately used and the final product quality suffers. Partial washout develops on the crushing tool, which leads to a reduction in crushing capacity and a shorter service life of the crushing tool.

Fines in the feed material must generally be avoided.

Rule of thumb: the supplied content of fines of 0-5 mm should not exceed 5%!

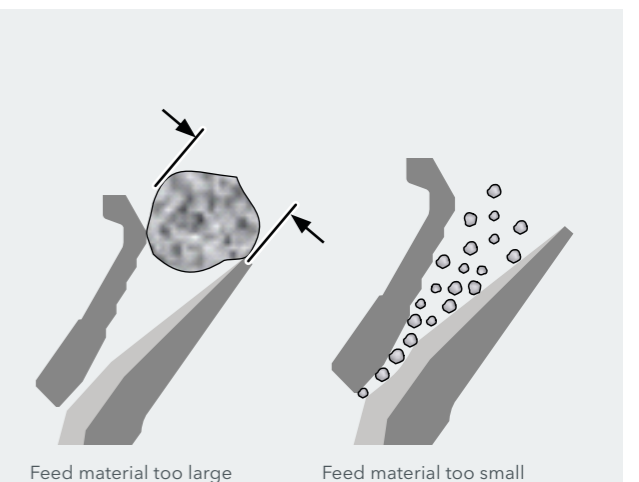

Feed material too large

Feed material too small

EFFECTIVE OVERLOAD SYSTEMS

Protect the plant.

Various short-term or prolonged overload situations can arise during the crushing process. With the MOBICONE MCO 90(i) EVO2 cone crusher, the intelligent automation systems protect against damage and failures.

The "Tramp Release" integrated overload system protects the crusher against uncrushable material such as wood or metal.

The bowl including the bowl liner lifts to allow uncrushable material to fall through - and the plant remains protected.

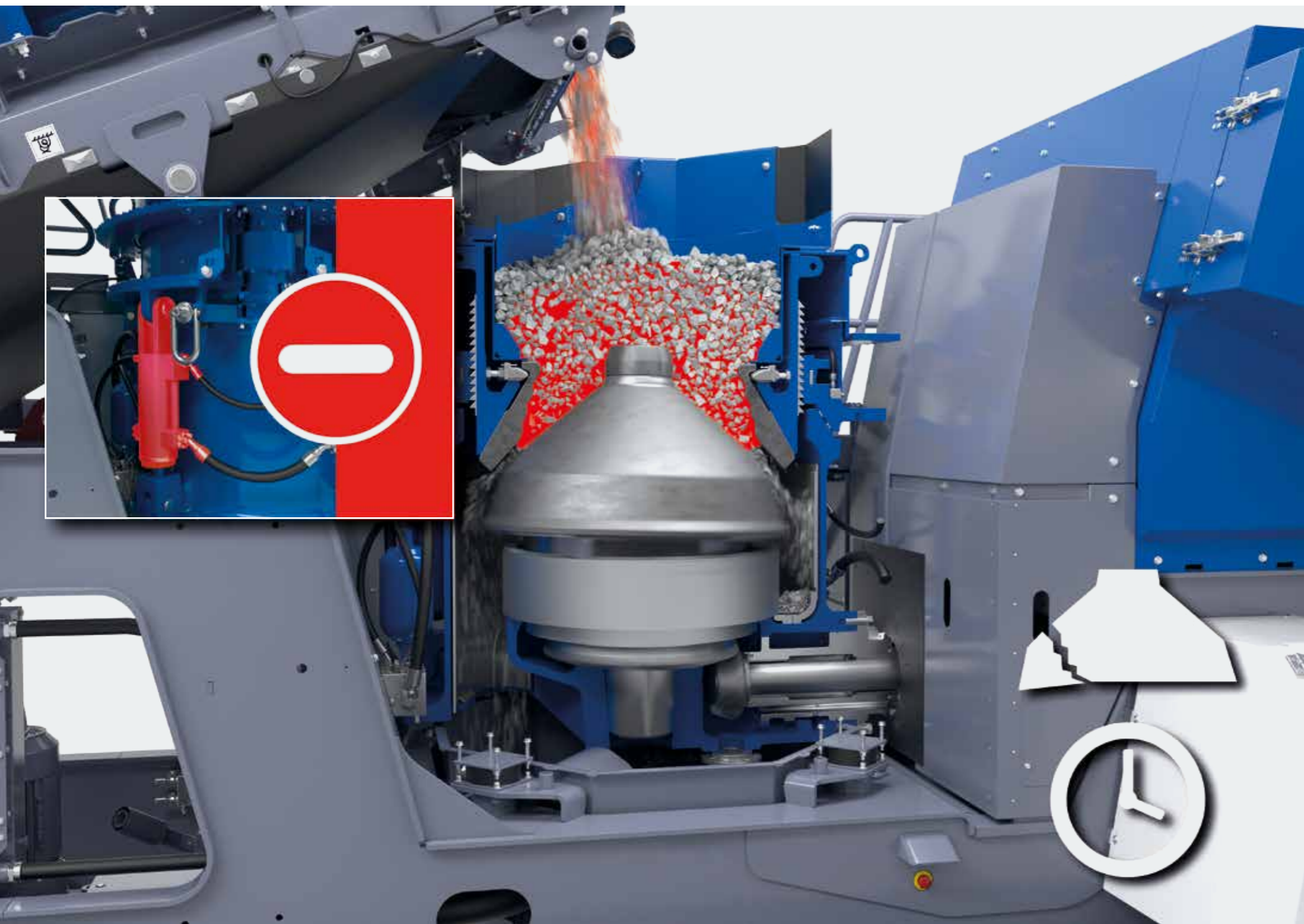

Additional overload detection is provided by the intelligent "Ringbounce Detection". Here, the hydraulic pressure and other parameters of the crusher are continuously monitored. If necessary, the system reacts and prevents latent overloads that could cause serious damage.

Two modes can be set in the software:

1



• **PRECISE MODE for the production of grit**

- > The machine stops feeding as soon as ringbounce is detected; the operator receives a fault message and can adapt the process.
- > In this mode, no additional impermissible oversize grain is produced and the machine is protected against crusher damage

2



• **MIXTURE MODE for the production of mixtures**

- > In this mode, the machine adapts the crushing gap automatically - without operator intervention - to avoid ringbounce.
- > After a definable time without ringbounce, the gap is closed again.
- > With virtually uninterrupted operation, the system automatically adjusts the gap, oversize particles are accepted or, in the case of operation with a post screening unit, returned to the circuit.

INNOVATIVE DRIVE CONCEPT

Impressive performance - with the best possible consumption values.

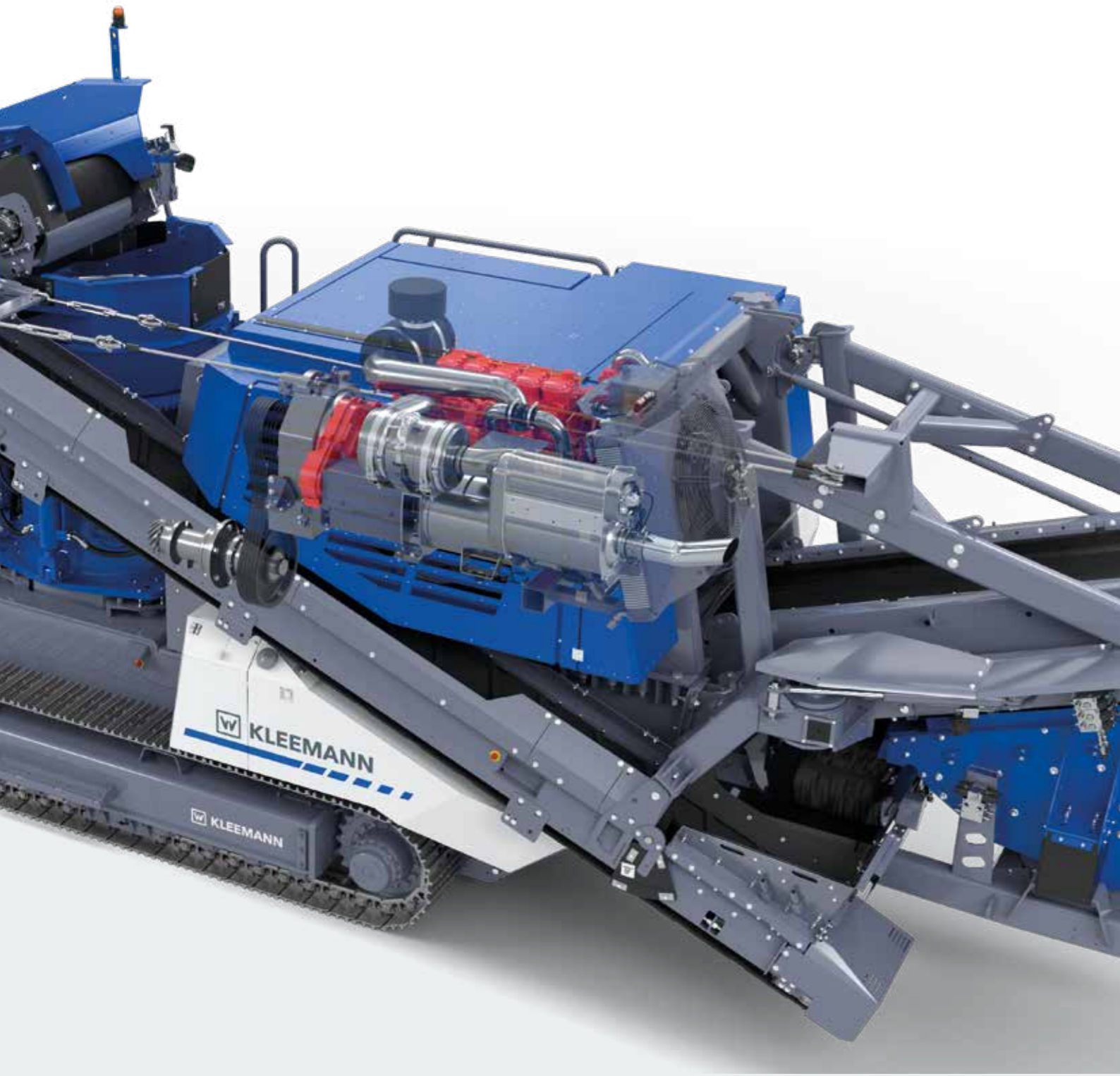

KLEEMANN
SUSTAINABILITY



The MOBICONE MCO 90(i) EVO2 features the innovative D-DRIVE "diesel-direct-electric" drive concept - making it both powerful and economical.

The MCO 90(i) EVO2 excels with its holistic drive concept with an efficient D-DRIVE diesel-direct drive whereby the crusher is driven directly via a fluid coupling from the diesel engine. The power- and load-dependent fan ensures a low-noise and even more economical operation. Via a power splitter gearbox, the generator is driven by a large cardan shaft, which means that the more maintenance-intensive timing belts are not required. The drive system pumps are activated via a clutch

coupling and can therefore draw on the full power of the diesel engine - for an enhanced driving performance. All other hydraulic pumps for auxiliary and set-up functions as well as for the cooler drive are also driven via the gearbox.

The plant can be optionally equipped with a heat package (-15 to +50 °C) or cold package (-25 to +40 °C).



D-DRIVE crusher direct drive: The fluid coupling guarantees high operational safety - for both the operator and the machine. All auxiliary drives such as the conveyor belts are driven electrically.

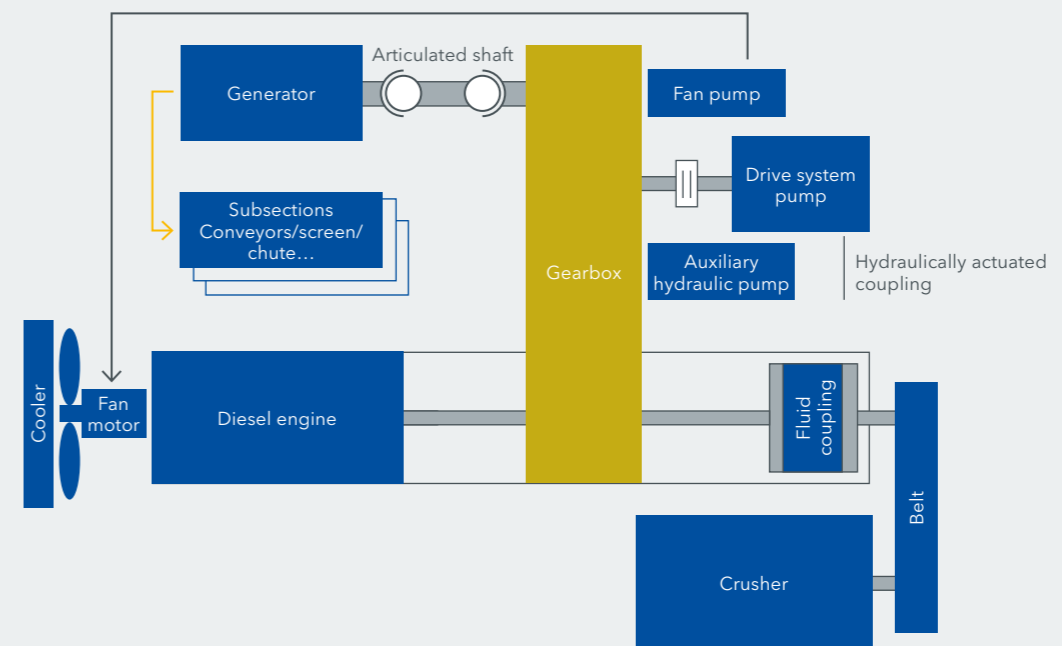

Diesel-direct-electric
D-DRIVE

287 - 289 kW
drive output



up to 30% less consumption
compared to hydraulic drives

SPECTIVE INTUITIVE OPERATING CONCEPT

For a better result - guaranteed.

With the increasing demands that are placed on modern crushing plants, their complexity also increases. At the same time, the technology must be safe and as simple as possible to master - and without long training sessions. This is precisely the strength of the SPECTIVE operating concept.

The MOBICONE MCO 90(i) EVO2 can be operated simply and intuitively with the various SPECTIVE components. Along with the touch panel, the holistic operating concept

includes a large and small radio remote control, and the SPECTIVE CONNECT digital solution.



01 Touch panel and operating buttons

From the start-up process to carrying out initial settings, and from troubleshooting to maintenance - SPECTIVE provides users with all important system information clearly presented on a 12" touch panel and allows all system settings to be made in one place. The optimised key arrangement below the display is self-explanatory in combination with the display and ensures a high level of operating comfort. The lockable operating mode selector switch also protects against operating errors. The user guidance and the visualisation of the operating process are displayed even more clearly. The troubleshooting aid contributes to minimising downtimes.

02 Radio remote control

The new radio remote control enables operation of all plant functions, including the complete set-up and driving operation, from a safe distance. Once it has been set and put into operation in automatic mode, the operator no longer has to go to the plant for most procedures. Furthermore, advantages in the field include the long battery runtime (> 10h) with LED for battery charge indication, a battery change without tripping an emergency stop and a very long range.

03 Small radio remote control

Due to its compact size, the small radio remote control is suitable for taking along in the loader. This means that all relevant functions can be conveniently operated in automatic mode in the excavator or wheel loader. The small radio remote control is the ideal complement to SPECTIVE CONNECT.

04 SPECTIVE CONNECT

With SPECTIVE CONNECT, users receive a display of the user interface via smartphone anywhere they may be working - for example, in the excavator or wheel loader. Along with relevant data such as speed, consumption values and fill levels, fault messages or warnings are also displayed. In addition, important process and machine data can be summarised in a report and conveniently transmitted.

Smart Job Configurator

Different machines, different settings - the Smart Job Configurator is available in SPECTIVE to help users find solutions quickly and easily. It allows the optimal machine settings to be easily determined.

- > Data of the planned application is entered in SPECTIVE CONNECT and the optimum machine settings are calculated automatically
- > Via the SPECTIVE touch panel, the calculated settings can be easily transferred to the machine by means of an input mask.

i The Smart Job Configurator can also be used without SPECTIVE CONNECT as a "QuickStart" on the touch panel.

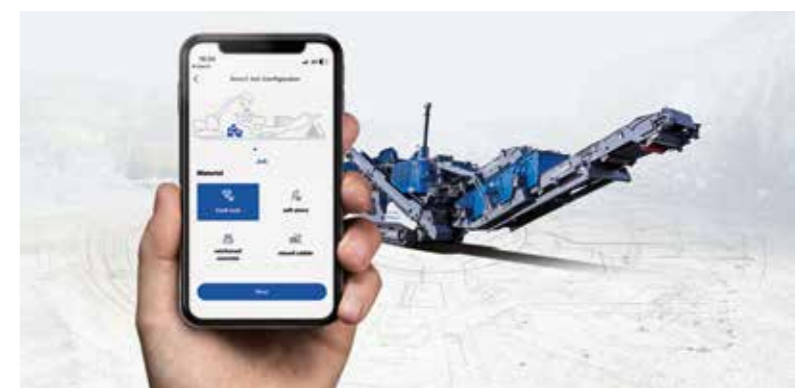

SPECTIVE CONNECT

Your plant data on the smartphone.

SPECTIVE CONNECT is the logical extension of SPECTIVE, because it brings the crusher's human machine interface into the excavator or wheel loader and therefore directly to the operator.

SPECTIVE CONNECT can be used to display all relevant operating data such as engine speed, consumption, throughput (in conjunction with belt scale) and fill levels of the MCO 90(i) EVO2, as well as fault messages, warnings and

other messages. Work, therefore, does not need to be interrupted to view the status. The option for preparing and sending a clearly arranged report creates additional transparency for the operator.

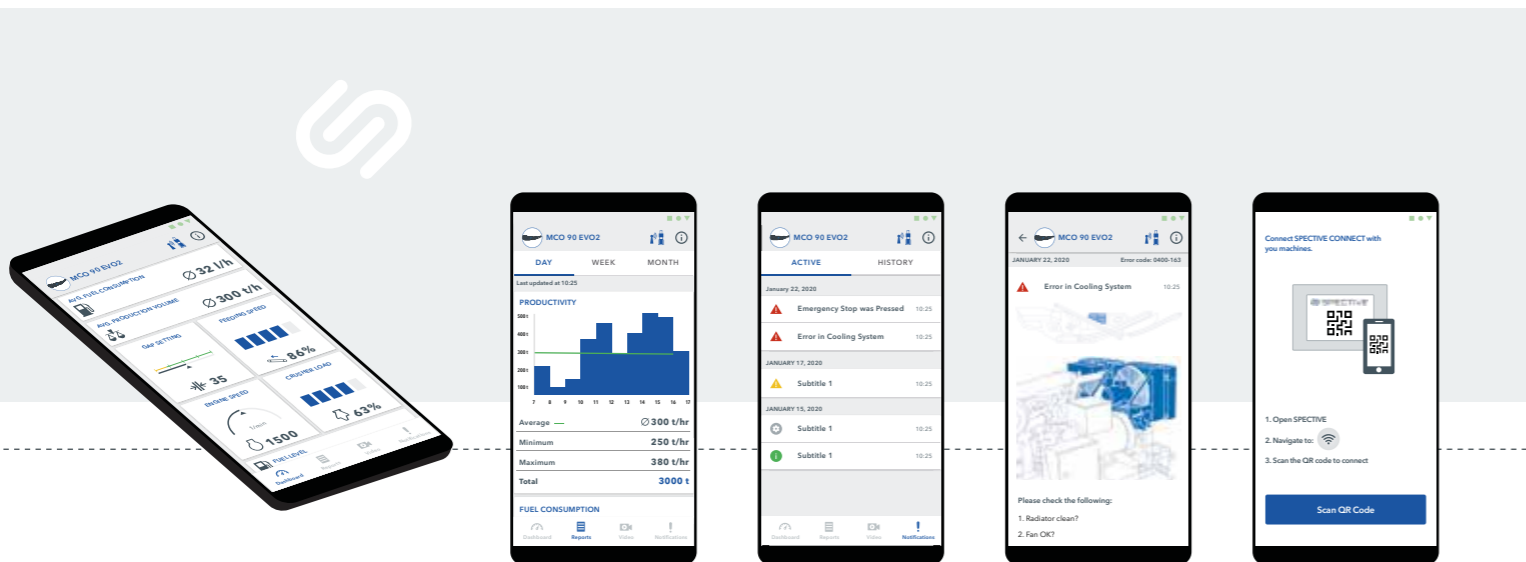

02 Fault elimination aids

All active errors incl. error history, warnings and messages can be displayed analogue to the SPECTIVE touch panel. The operator knows what to do and is also specifically supported in troubleshooting via troubleshooting aids.



01 Dashboard

A language-neutral display clearly shows all crushing plant information of relevance to the operator:

- > Average fuel consumption
- > Average production output
- > The current gap setting
- > Speed and utilisation
- > Feed speed
- > Fill levels



03 Reporting

A clearly arranged report on operation and output of the crushing plant allows the operator and operating company to draw conclusions on current plant utilisation.

The following can be displayed:

- > Average fuel consumption
- > Average production output (belt scale for crusher discharge conveyor)
- > Plant utilisation (when is the plant stationary, when is it fully utilised, ...)

The reports can be sent conveniently as a PDF.

KLEEMANN > GOOD TO KNOW

Is your plant ready for SPECTIVE CONNECT?

If your plant is equipped with the SPECTIVE CONNECT option, then simply download the app for your smartphone and get started!

1. Select the WiFi symbol on the SPECTIVE start screen.
2. Scan the QR code and you will be connected with the plant immediately.

Following this, the connection is always established when you are close to the machine.



Scan the code for further information on SPECTIVE CONNECT



The availability of SPECTIVE CONNECT depends on country-specific conditions. Further information can be obtained from your local contact person or at www.wirtgen-group.com/spective-connect-kleemann

POST SCREENING UNITS

Effective for the final product.

The MCO 90(i) EVO2's optional post screening units allow up to two defined grain sizes to be screened.

The large screening surface with optimal screen usage enables effective screening even for grain sizes below 20 mm. The discharge height is designed for a high stockpile volume and optimally tuned to the transfer to the subsequent crushing or screening stage. The assembly and disassembly of the post screening units can be carried out quickly and easily in just a few minutes.

Oversize grain can be processed in a closed material circuit via a return conveyor. As an option, the conveyor can be swivelled

hydraulically by up to 100°, which also enables side discharge. A kidney-shaped stockpile can therefore be created manually.

Note: The MCO 90(i) EVO2 can also be retrofitted with a post screening unit. The more powerful generator this requires can also be provided in the initial configuration.



KLEEMANN > PROCESS KNOWLEDGE

Oversize grain circuit, cone crushing plant with single-deck post screening unit



- 01** Material feeding
- 02** Transport of feed material via the feeding conveyor
- 03** Pressure crushing in the cone crusher
- 04** Transport of crushed material via the crusher discharge conveyor onto the single-deck classifying screen
- 05** Diffusor for better material distribution
- 06** Single-deck classifying screen
- 07** Discharge of the oversize grain via the transfer conveyor onto the return conveyor
- 08** Return conveyor with discharge onto the feeding conveyor
- 09** Discharge of the classified final product via the fine grain conveyor

Single- or double-deck vibrating screen
highly efficient even with small grain sizes < 20 mm

Assembly and disassembly
can be carried out in just a few minutes

ACCESSIBILITY AND SAFETY

For high operating comfort.

A machine needs to be easy to operate and safe, but convenient maintenance is also very important to the operator.

All machine components are especially easy to access to guarantee trouble-free production, simple operation and fast service. A central drain point for fluids, for example, makes

ergonomic maintenance possible. Spray systems at different transfer points, as well as LED lighting for illuminating the work area, are included in the basic configuration of the plant.

Central drain point



Additional options increase operating comfort

Optionally available Premium lighting provides even better illumination of the machine environment. Simple refuelling of the machine is possible from the ground or with the help of a refuelling pump for filling from tanks.

Safety is always in the foreground

The MOBICONE MCO 90(i) EVO2 is also ideally equipped when it comes to safety. All function- and safety-related cylinders are equipped with safety valves (lowering/brake holding valves). Each cylinder stays in its current position - to protect the machine operator and machine in the event of deactivation or failure. Thanks to plant operation from a safe distance via the radio remote control, safety on the work site is increased.



● Standard lighting + Premium lighting □ Mobile work lamp

Standard lighting

The standard lighting includes the illumination of the travel path, the steps and the area of the touch panel. A USB charging port for a mobile maintenance lamp is also available.

Premium lighting

The premium lighting includes a large number of headlamps for extended illumination of the machine as well as a mobile maintenance lamp.

SIMPLE TRANSPORT

Quickly on site. Immediately ready for work.

The MOBICONE MCO 90(i) EVO2 cone crusher is versatile, compact and easy to transport.

The MCO 90(i) EVO2 can be used for diverse applications and is quickly ready for operation. And even if the work location changes frequently, the machine is can be quickly loaded and transported thanks to its relatively light weight.

After arrival at the work site, set-up times are very short: the feeding unit and conveyors can be conveniently moved into operating position hydraulically and from a safe distance with SPECTIVE radio remote control.

The post screening unit can remain on the machine for transport, although it can also be disassembled in just a few minutes. Thanks to its compact container dimensions, it is also easy to transport separately.

With a transport height reduced to 3,400 mm, transport is now even easier and more cost-effective - and all this including the post screening unit.



 **High flexibility**
for changing work locations

 **Short set-up times**
thanks to uncomplicated set-up

Low weight
makes it easy to transport

3,400 mm transport height
with and without post screening unit

ENVIRONMENTALLY FRIENDLY SOLUTIONS

For more sustainability.

The MOBICONE MCO 90(i) EVO2 is equipped with several environmentally friendly innovations.

The MCO 90(i) EVO2 is equipped as standard with an output- and load-dependent fan. This guarantees a low fuel consumption and reduces noise emissions. Thanks to ECO mode, fuel consumption can be reduced even further. If the machine is

not being loaded and is paused for a short time, all components - with the exception of the diesel engine and crusher - can be switched off by pressing a button. Power supply to all consumers is therefore not required.



ECO mode
for reduced fuel consumption and wear in idle phases

Water spray nozzles
in all relevant positions



KLEEMANN
SUSTAINABILITY

For dust reduction

Thanks to the water spray nozzles at all relevant positions such as the crusher inlet, crusher discharge conveyor and the post screening unit, most of the dust is bound together in the process, preventing it from spreading. Various optional belt covers for the discharge conveyors can also be used for dust minimisation.



KLEEMANN SUSTAINABILITY

Thanks to the output- and load-dependent fan, the basic configuration of the plant is very low-noise, which makes work near the machine a lot more pleasant and easier on the operator.

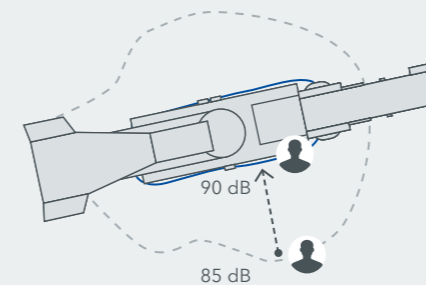

MCO 90(i) EVO2

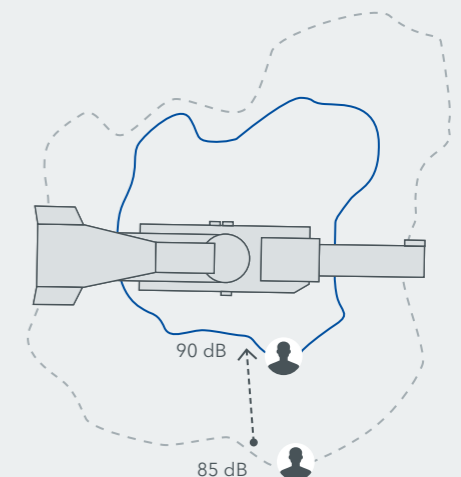

MCO 9 EVO

IDEALLY COMBINED

For perfect processes.

Process-related knowledge

The line coupling option allows KLEEMANN machines to be coupled with each other. The crushing process between the crushing plants is then optimised automatically so that material is always conveyed through the machines with maximum efficiency. A probe is installed at the crusher discharge conveyor and/or fine grain conveyor of the upstream machine, which monitors the fill level of the feeding unit of the respective downstream machine. When the fill level reaches a defined height, the output of the upstream plant is temporarily reduced.

For safety reasons, the crushing and screening plants are connected to each other by a cable. If an emergency stop button is pressed on the plant train in the event of an emergency, all machines are safely stopped.

MC EVO2 + MCO EVO2 + MSC EVO

TARGETED TO SUCCESS

For perfect crushing results.



An optimum crushing result is always achieved by means of the ideally matched components of the overall plant and the settings made by the operator.

Before implementing the project, it is important to know the full details of the application and make important preparations. Our KLEEMANN experts will gladly support you!

Important basic points

- > What do I want to achieve with my application? Define the objective of the application: output and/or quality
- > What exactly does my application look like? Take material samples and have them examined
- > Which machines are suitable for the application? KLEEMANN will support you with the AggFlow preparation

- > Which tools do I have to use? Info can be found in AggFlow
- > Do I have personnel trained for a cone crusher? KLEEMANN will train your personnel during commissioning
- > Have provisions been made for maintenance and spare part supply? Discuss this with your Service contact person

Cone crushing plants' areas of application

NATURAL STONE

Limestone / sandstone / greywacke / gravel / granite / gneiss / marble / quartzite / diabase / gabbro / basalt	Iron ore	Coal	Clay

With these tips, it is possible to find the ideal settings for any task:

Well filled crushing chamber

- > Guarantees the throughput because a higher crushing effect is created in the crushing gap

Correct feed size

- > Has a strong influence on the crushing result, wear and the output of the cone crushing plant

Centric feeding of the feed material

- > Ensures a homogeneous distribution in the crushing chamber

Crushing ratio

- > The maximum crushing ratio (ratio of feed grain size / grain output) largely depends on the physical properties of the feed material. The following standard values result:

Uniform feeding

- > Guarantees a stable process
- > Uniform feeding through the correct selection of the crushing tools, the crushing gap and the correct setting of loading via the CFS

CRUSHING RATIO				
Specification	Crushing stage	Compressive strength	Circuit	Reduction ratio
standard head	secondary	<300 Mpa	open/closed	4:1
short head ¹	tertiary/quaternary	<300 Mpa	open/closed	3.5-4.5:1
short head ²	tertiary/quaternary	<300 Mpa	open/closed	2-3:1

¹ normal grain shape requirements
² high grain shape requirements



KLEEMANN > GOOD TO KNOW

In order to successfully carry out projects with mobile cone crushers, it is important to know the application and to collect all important information. This questionnaire will help you. Find out more at www.wirtgen-group.com/questionnaire-kleemann



For further information, scan the code

CONE CRUSHER 1 X 1

For a trouble-free work process.

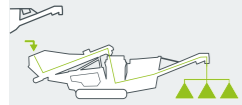

Prior to starting: check process (AggFlow)

Before embarking on a new application, you have to check whether the installed tool is suitable for the task and which crushing gap can be operated. A check must be carried out to determine whether the cone crusher can process the feed material without any problems - to prevent damage caused by excessively coarse or fine material.

Process simulation (AggFlow) can provide support in this area.

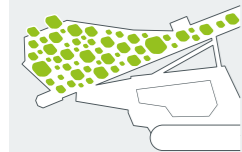

Fill evenly, avoid running empty

A material layer should always be present in the feed hopper, as this cushions the load of newly fed material and therefore reduces the wear on the feed hopper.

Overfilling the hopper can lead to blockages and the material can no longer reach the crusher in a trouble-free manner. If the feed hopper is not filled evenly, this results in a fluctuating filling level and empty running of the cone crusher.

With the following negative consequences:

- > Flaky product
- > Increased share of coarse grains
- > Increased and uneven wear
- > Bearing damage through abrupt loading

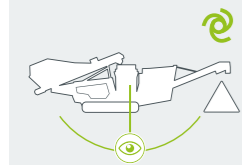

Regular process monitoring during operation

- > Regular monitoring of the process is absolutely necessary to guarantee a uniform material flow. Overloading can be identified early and damage can be avoided.
- > Ensure that the hoppers are never overfilled; it may be necessary to adapt the process parameters. On material return sections, ensure that there is not too much material in the return flow; it may also be necessary in this case to adapt the process parameters.



Observing maintenance and inspection intervals

Regular maintenance and observance of the inspection intervals increase plant availability and therefore the total production output.

Regular maintenance and inspection allows damage to be avoided or to be identified in good time, therefore preventing long downtimes. The maintenance intervals are listed in the instruction manual.

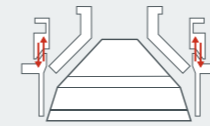

Adapting the process in the event of overload

- > Watch out for overloading and keep the Ringbounce Detection overload system activated.
- > Signs of overloading include frequent tripping of the overload system, crusher stops, pulsating hydraulic hoses or a vibrating bowl (micro-vibrations).

Countermeasures:

- > The feed material must be pre-crushed to make it smaller or fine material must be prescreened.
- > Increase in gap size and, where necessary, increase in speed.



Avoid wet, sticky feed material

- > Wet, sticky feed material causes jamming and clogging of the crushing chamber. This reduces the throughput and, as clogging of the crushing chamber increases, the feed material can become briquetted, which leads to blocking of the crushing process. The resulting uncontrollably high forces lead to permanent damage of the cone crusher or its failure.

Countermeasures:

- > Avoid feeding with wet, sticky feed material; if necessary, pre-separate sticky material by means of prescreening. A clogged crushing chamber needs to be cleaned.

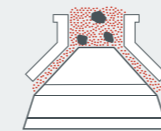

Avoid fines

- > When fine material is fed in, tool wear is significantly higher than with prescreened feed material. Fines also lead to an increase in the crushing forces and the drive output is then possibly no longer sufficient. An excessive content of fines can trigger a latent overload (ringbounce) and lead to permanent crusher damage.

Countermeasures:

- > Activate prescreening at the upstream jaw crusher and separate the fines. Alternatively, cut in a screen upstream of the cone crusher to separate the fine aggregate.

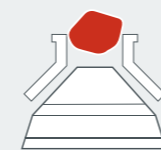

Observe correct feed size

- > If the feed material is too large, the material will not be drawn sufficiently into the crushing chamber and material blockages form. The result is a reduced crushing capacity, increased or uneven wear as well as damage to the crusher.
- > If the feed material is too small, the power of the crusher is not adequately used and product quality suffers. Partial washout can develop on the crushing tool. This can lead to a reduction in the crushing capacity, quality and a shorter tool service life.

Countermeasures:

- > Select the tool to match the feed size or adapt the feed size to match the tool. Only feed material with a uniform grain size distribution and avoid gap grading.

YOUR WIRTGEN GROUP CUSTOMER SUPPORT

Service you can always rely on.

Place your trust in our reliable and fast support during the complete life cycle of your machine. Our wide service offer includes suitable solutions to meet all of your challenges.



Service

We keep our service promises - with fast and uncomplicated assistance both on the building site and in our professional workshops. Our Service team has received expert training. Thanks to special tools, repair, care and maintenance work is completed quickly. Upon request, we can support you with tailored service agreements.

> www.wirtgen-group.com/service



Spare parts

Original parts and accessories from WIRTGEN GROUP can ensure the high reliability and availability of your machines in the long term. Our experts will be glad to advise you on application-optimised wear part solutions. Our parts are available worldwide, at any time and are easy to order.

> parts.wirtgen-group.com



Training

Staff responsible for the WIRTGEN GROUP's product brands are specialists in their areas and have decades of application experience. Our customers also greatly benefit from these experts. In our WIRTGEN GROUP training courses, we gladly pass on our knowledge to operators and service personnel.

> www.wirtgen-group.com/training



Telematics solutions

Construction machines with leading technology and perfected telematics solutions work hand-in-hand in the WIRTGEN GROUP. The Operations Center* - the digital platform for process, machine and service optimisation - enables you to not only simplify maintenance planning for your machines, but also to increase your productivity and cost-effectiveness.

> www.wirtgen-group.com/telematics

* The John Deere Operations Center™ (formerly WITOS) is currently not available in all countries. Please consult your responsible subsidiary or dealer if you have any questions.

CRUSHING TOOLS

The right wear parts for the best results.

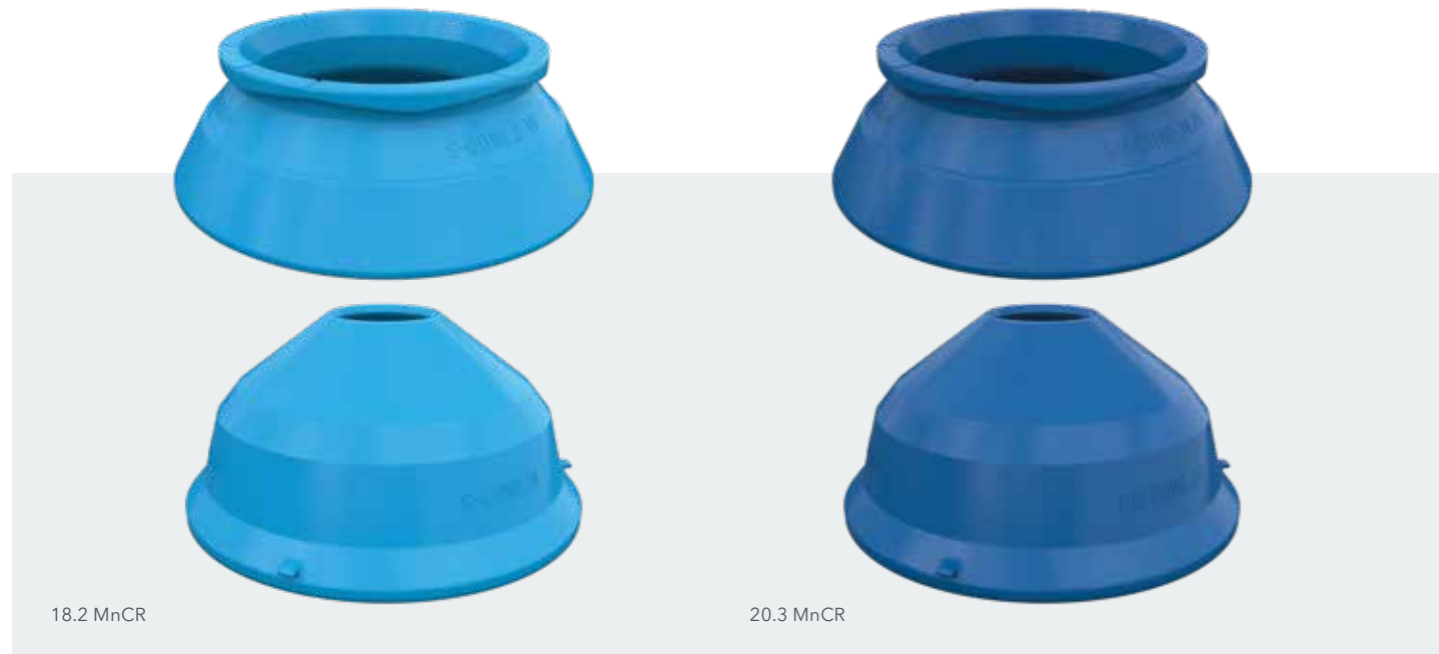

Cone crushers are mainly used when impact crushing is no longer possible due to the high compressive strength of the crushed material, or the wear costs due to the abrasiveness of the stone cannot be economically justified.

Due to their design, cone crushers are limited in terms of the feed size and the achievable reduction ratios. The plants are mainly used for recrushing in the secondary and tertiary crushing stage. Different CONE crushing tools are available.

USE OF THE CONE CRUSHER TOOLS

Application	Marking for identification	Max. F. Size	Closed side setting in mm (CSS)	Cast alloy	Design
Secondary crushing stage > For final product > 25 mm > Reduction ratio* 3.5 to 5:1 > Open circuit > Large feed opening	Notch on one side	116 - 131	16 - 32	MnCr 18.2	S-CONE F.18
		138 - 157	19 - 38	MnCr 20.3	S-CONE F.20
		179 - 199	25 - 45	MnCr 18.2	S-CONE M.18
				MnCr 20.3	S-CONE M.20
				MnCr 18.2	S-CONE C.18
				MnCr 20.3	S-CONE C.20
Tertiary / quaternary crushing stage > For final product < 25 mm > Reduction ratio* 2.5 to 3:1 > Closed circuit > Long calibration zone	Notch on two sides	71 - 80	10 - 19	MnCr 18.2	SH-CONE F.18
				MnCr 20.3	SH-CONE F.20
		99 - 111	10 - 22	MnCr 18.2	SH-CONE M.18
				MnCr 20.3	SH-CONE M.20
		130 - 142	13 - 25	MnCr 18.2	SH-CONE C.18
				MnCr 20.3	SH-CONE C.20

APPLICATION-SPECIFIC WEAR PARTS

Crusher cone - versions

- > Standard
- > Short Head

Bowl liner - versions

- > Standard Fine
- > Standard Medium
- > Standard Coarse
- > Short Head Fine
- > Short Head Medium
- > Short Head Coarse

The correct combination is what counts!

In order to produce a constant high material volume from a cone crusher with high final product quality, mobile cone crushers should be operated in the optimum range.

This starts with the selection and composition of the correct tool, which consists of cone and bowl liner.

Secondary crushing stage

- > final product > 32 mm
- > open circuit
- > large feed opening

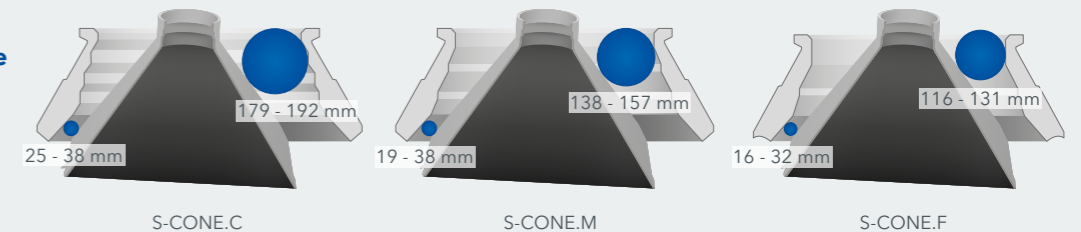

Tertiary crushing stage

- > final product < 32 mm
- > closed circuit
- > long calibration zone

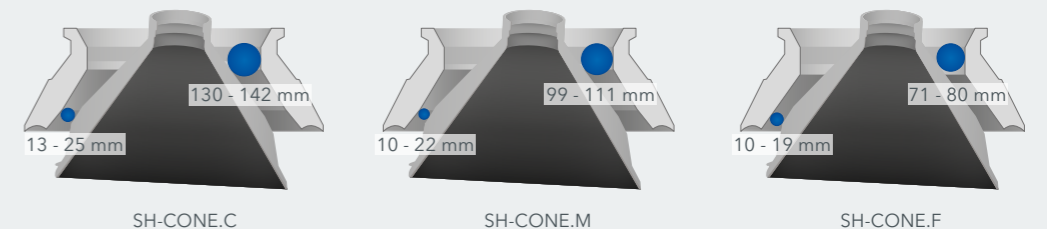

- > S-CONE stands for the Standard version
- > SH-CONE stands for the Short Head version

Further information: parts.wirtgen-group.com

TECHNICAL DATA AT A GLANCE

MOBICONE MCO 90(i) EVO2



TECHNICAL DATA *

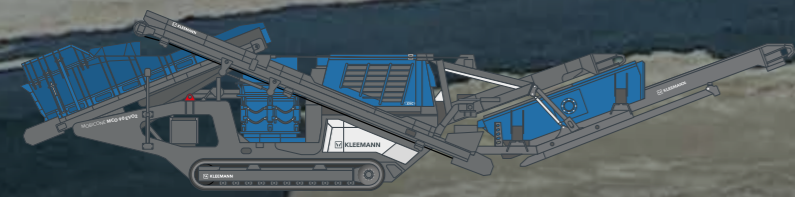

MCO 90(i) EVO2

- > Crusher system size (d) = 970 mm
- > Feed capacity: 270 t/h
- > Weight: 33,500 - 49,000 kg

* Illustration contains options

**KLEEMANN GmbH**

Manfred-Wörner-Str. 160
73037 Göppingen
Germany

T: +49 7161 206-0

M: info@kleemann.info

 www.kleemann.info